



TREKHAKEN • ATTELAGES • ANHÄNGERVORRICHTUNGEN • TOWBARS • ENHANCES • ANHÆNGERTRÆK

Montagehandleiding | instructions de montage | Einbauanleitung | Mounting instruction
Instrucciones de montaje | monteringsvejledning



SsangYong/KGM Korando (type C300, CW) 03/'19-

- ✓ STANDARD
- ✓ AD BLUE
- ✓ E-MOTION

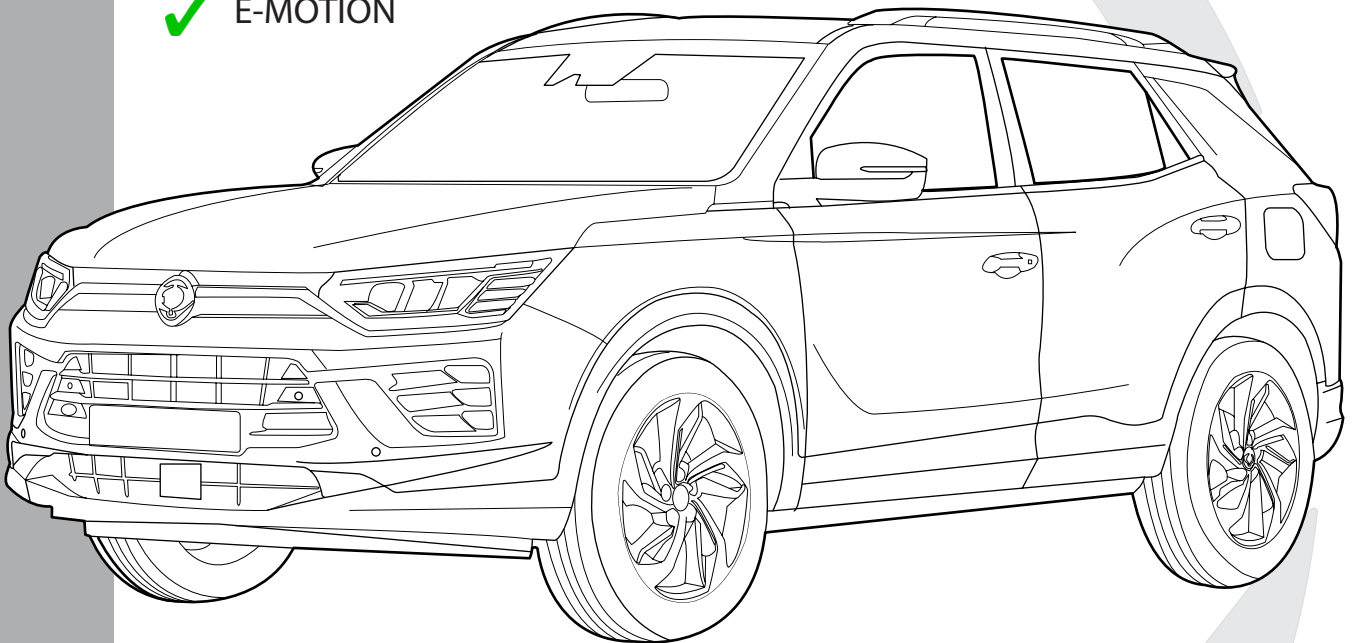

SCAN FOR THE
LATEST VERSION



NL Belangrijke raadgevingen

Montage

- Voor de montage moet de trekhaak eerst op het voertuig gepresenteerd worden.

De belasting van een aanhangwagen en van een accessoire dat op de koppelingskogel wordt voorzien, zijn anders van aard. Voor beiden kunnen verschillende limieten van toepassing zijn. Hiervoor verwijzen we naar het instructieboekje van de wagen of naar uw concessiehouder.

FR Recommandations importantes

Montage

- Présenter l'attelage sous le véhicule avant d'effectuer le montage.

La charge d'une remorque ou d'un accessoire monté sur la boule d'attelage, sont de nature différentes. Des limites différentes peuvent s'appliquer à l'un et à l'autre. Nous vous recommandons de vous référer à votre livret d'instructions ou de vous renseigner chez votre concessionnaire.

EN General instructions

Fitting

- Present the towbar under the car first to check if all points are right.

The load of a trailer and of an accessory fitted on the towing ball are of a different nature. Different limits may apply to both. For this matter, we refer to the instruction manual of the vehicle or we advise you to contact your concessionaire.

DE Allgemeine Hinweise

Montage

- Halten Sie die Anhängerkupplung zunächst unter das Fahrzeug und prüfen Sie, ob alle Punkte übereinstimmen.

Die Last eines Anhängers und die Last eines an der Zugkugel montierten Zubehörs unterscheiden sich grundsätzlich. Für beide können unterschiedliche Grenzwerte gelten. Wir verweisen diesbezüglich auf die Betriebsanleitung des Fahrzeugs oder empfehlen Ihnen, sich an Ihren Vertragshändler zu wenden.

ES Instrucciones generales

Montaje

- Presentar el enganche debajo del vehículo antes de realizar el montaje.

La carga de un remolque y un accesorio montado en una bola de remolque son de una naturaleza diferente. Se pueden aplicar diferentes límites a ambos. Para este asunto, nos referimos al manual de instrucciones del vehículo o le recomendamos que contacte a su distribuidor.

DK Generelle instruktioner

Montering

- Præsenter trækstangen under bilen først for at kontrollere, om alle punkter er rigtige.

Belastningen af en trailer og af tilbehør tilkoblet anhängertrækket er forskellige. Der kan være forskellige begrænsninger på begge. I disse tilfælde henviser vi til bilens manual, eller anbefaler dig at kontakte bilforhandleren

IT Consigli importanti

Montaggio

- In primo luogo, presentare la struttura sotto l'automobile per verificare che tutti i punti di attacco coincidano.

La massa rimorchiabile del veicolo potrebbe essere diversa dal valore riportato sul documento del gancio di traino. Per questo motivo, vi invitiamo a consultare sempre la carta di circolazione del veicolo (Pos. O.1) o a rivolgervi alla vostro concessionario di fiducia

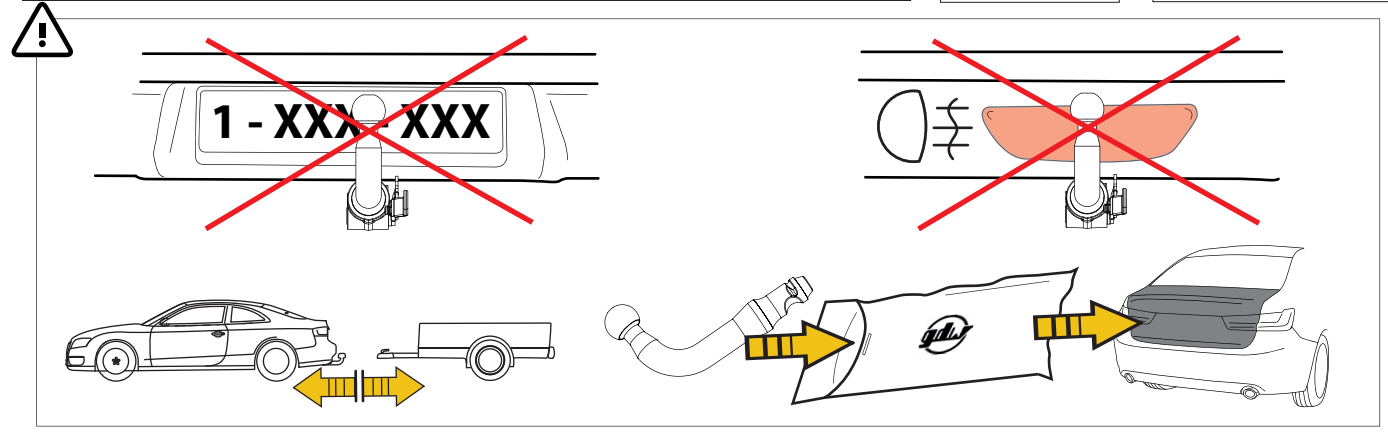
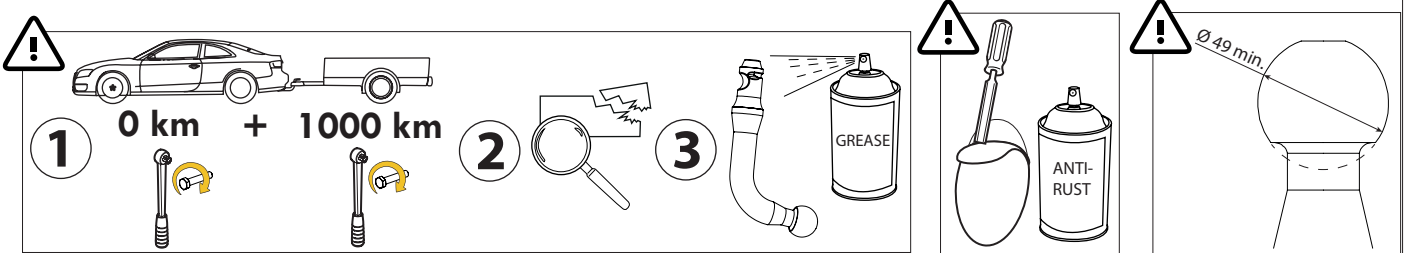
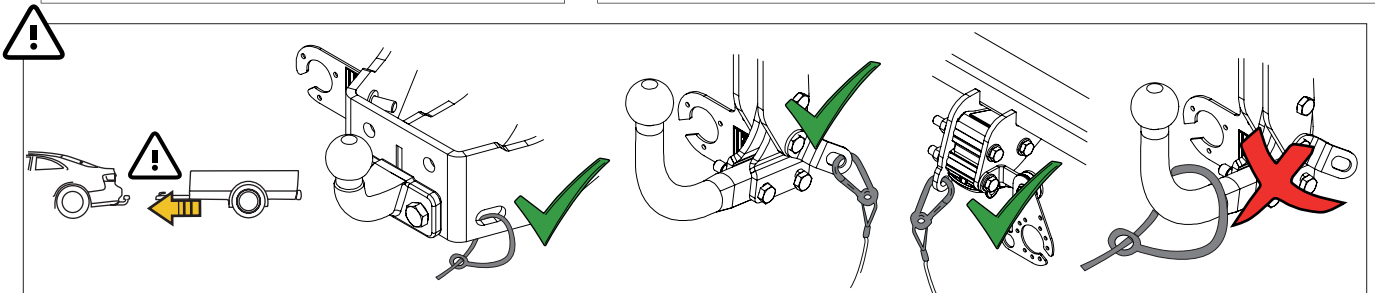
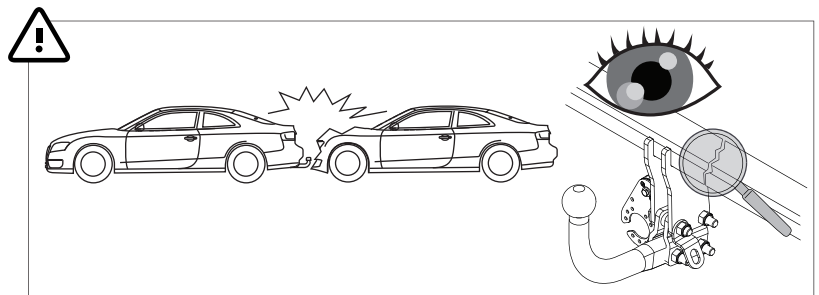
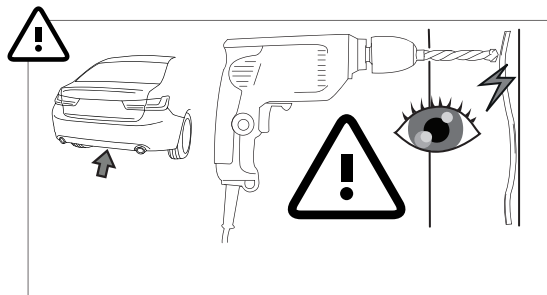
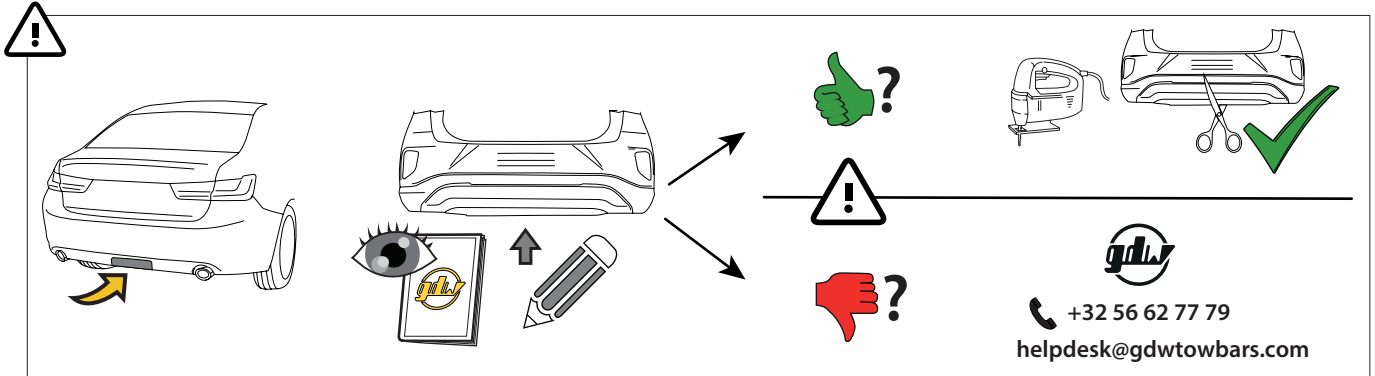
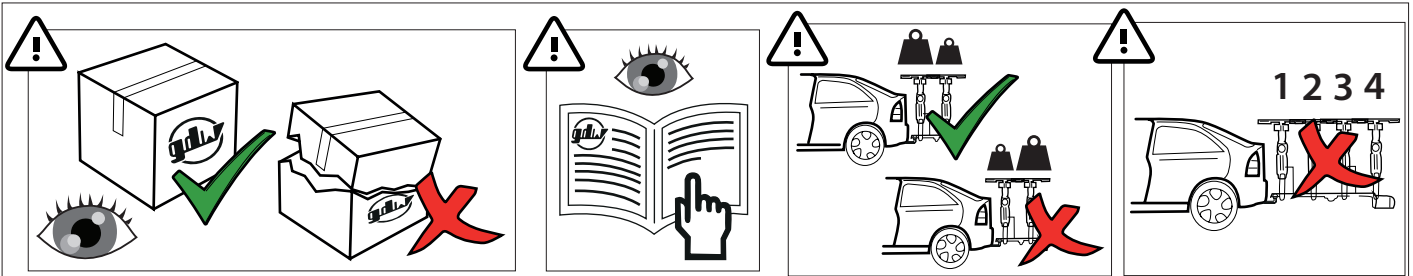

MADE BY 	D 10,40	F	E6
BELGIUM	S 115	EC-N° 55R-011594	
REF N° 2392T60		SERIAL N° XXXX	
DESCRIPTION SsangYong/KGM Korando (C300, CW) 03/'19-			

!

D = max kg **X** max kg **X** 0.00981 ≤ 10,40 kN

S = max kg **+** max kg

S = ≤ 115 kg **!** ≤ 2000 kg

! See the Certificate Of Conformity (COC) of your vehicle or contact your dealer to verify the max. trailer weight of your car!

! See the user manual of the vehicle for correct use of bicycle carriers!

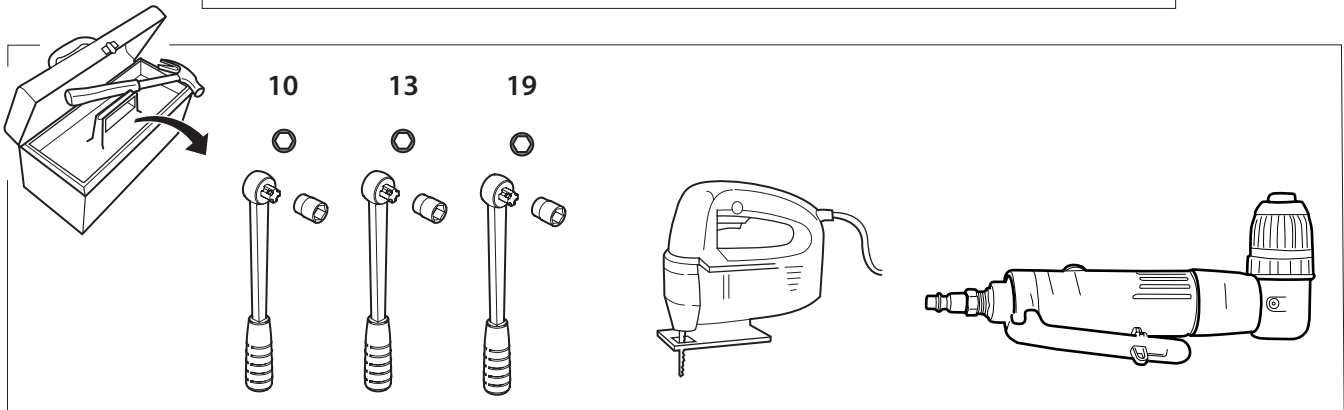
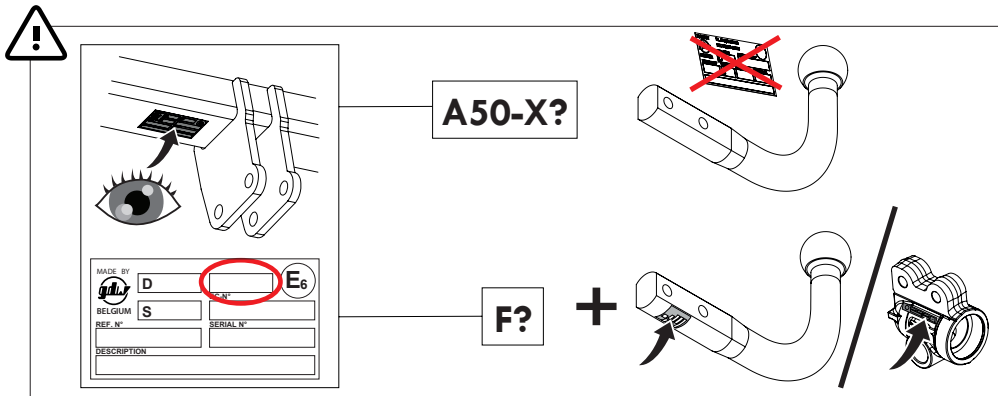
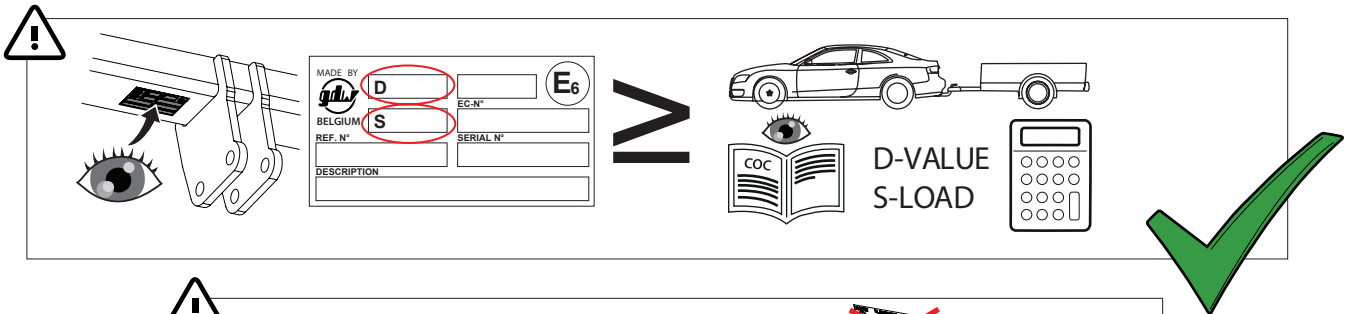
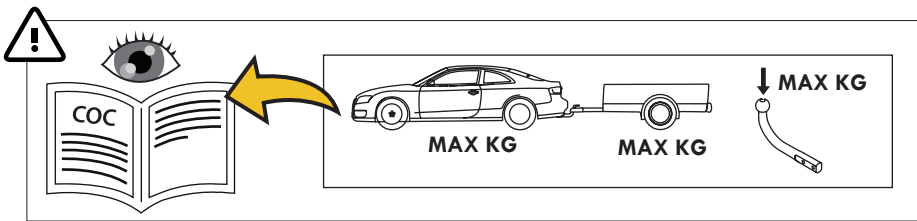

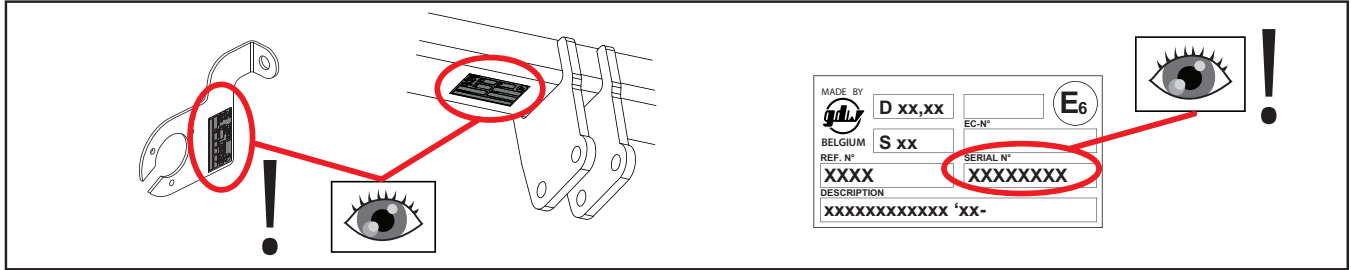





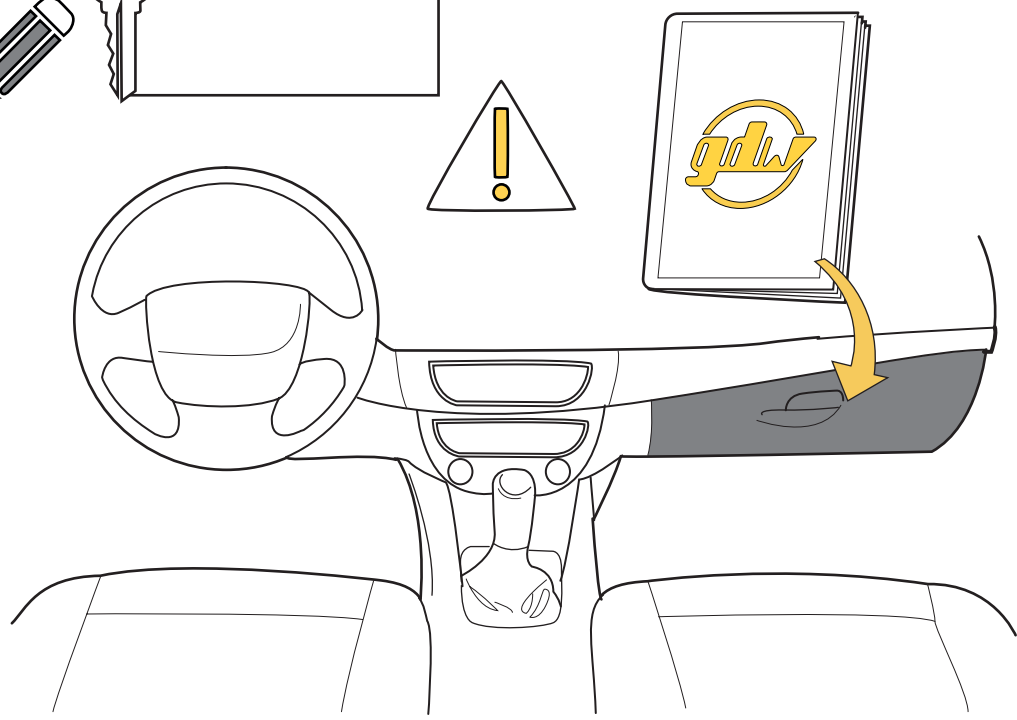

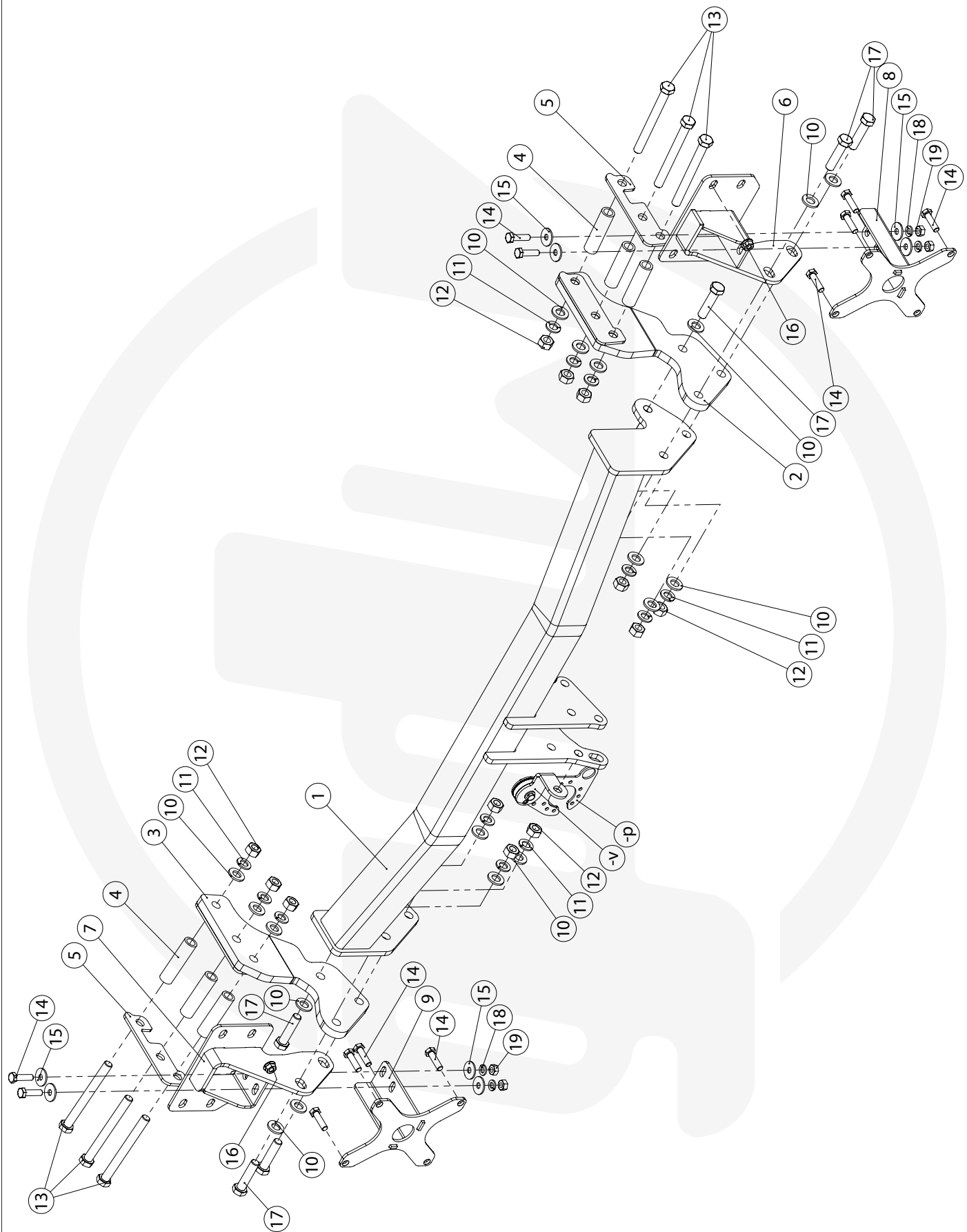

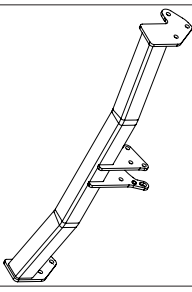
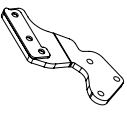
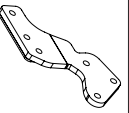

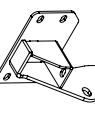
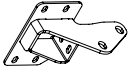
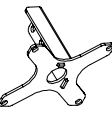
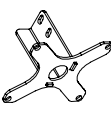





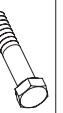

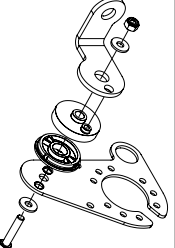



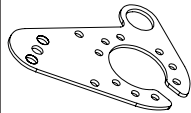

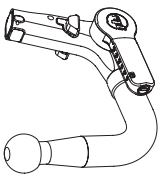

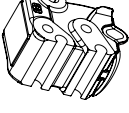

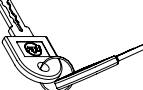
helpdesk@gdwtowbars.com
+32 56 62 77 79

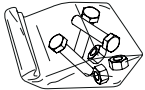
Monday	08:00 - 12:00	12:30 - 16:30
Tuesday	08:00 - 12:00	12:30 - 16:30
Wednesday	08:00 - 12:00	12:30 - 16:30
Thursday	08:00 - 12:00	12:30 - 16:30
Friday	08:00 - 12:00	12:30 - 15:30





1		X1	GDW REF. 2392160	
2		X1	GDW REF. 2	
3		X1	GDW REF. 3	
4		X6	GDW REF. 4	
5		X2	GDW REF. 5	
6		X1	GDW REF. 6	
7		X1	GDW REF. 7	
8		X1	GDW REF. 8	
9		X1	GDW REF. 9	
10		X18	DIN125-A12-14OHV-ELVZ	
11		X12	DIN128A-M12	
12		X12	DIN934-M12	
13		X6	DIN931-M12 X 120	
14		X12	DIN933-M8 X 30	
15		X8	DIN9021-M8-ELVZ	
16		X2	DIN6923-M8	
17		X6	DIN931-M12 X 50	
18		X4	DIN128A-M8	
19		X4	DIN934-M8	
-V		X1	GDW REF. 908,095	
-P		X1	GDW REF. P39	
↳		X1	DIN985-M6	
↳		X2	6,2 X 15,4 X 1,6 (NYLON)	
↳		X1	GDW REF. 718.16.002	
↳		X1	GDW REF. 718.16.003	
↳		X1	GDW REF. 908,094	
↳		X1	DIN933-M6 X 30	
↳		X1	GDW REF. 908,095	
Geleverd met - Livré avec - Delivered with Geliefert mit - Elementos adjuntos-Leveres med				
	X1	GDW REF. 960.V0808		
↳ 	X1	GDW REF. 740.200		
	X1	GDW REF. 912.003		
↳ 	X1	GDW REF. 740.112		
↳ 	X1	GDW REF. 740.111		
	X1	GDW REF. 740.114		
	X1	GDW REF. 718.15.001		
	X1	GDW REF. SYST60-10		
↳ 	X3	DIN931-M12X110-8.8		
↳ 	X3	DIN128A-M12		
↳ 	X6	DIN125A-M12		
↳ 	X3	DIN934-M12		

1

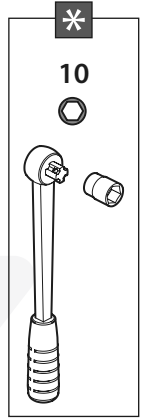
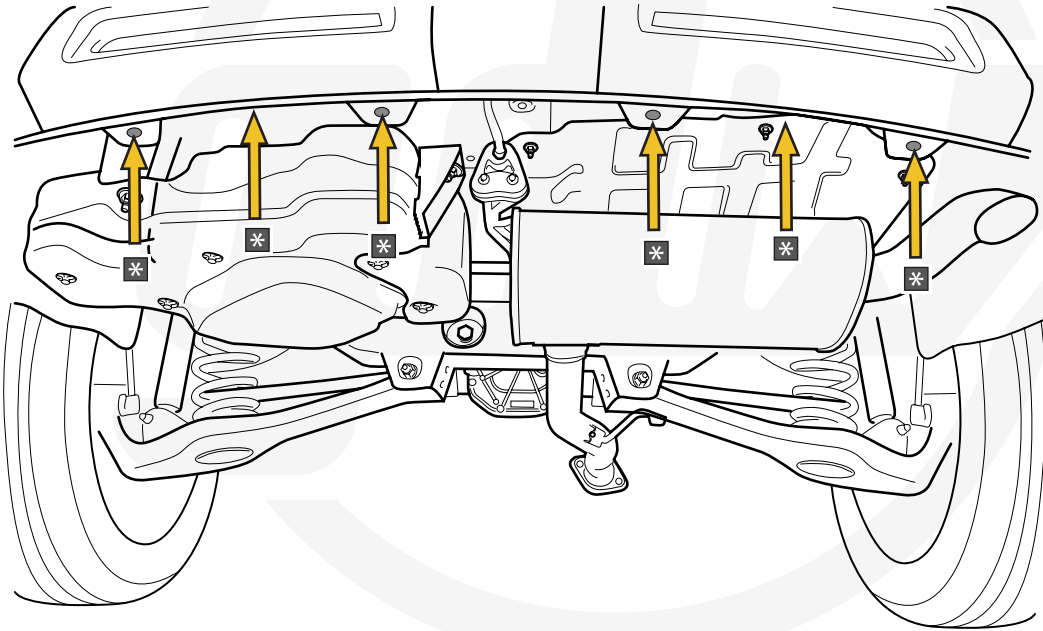

2

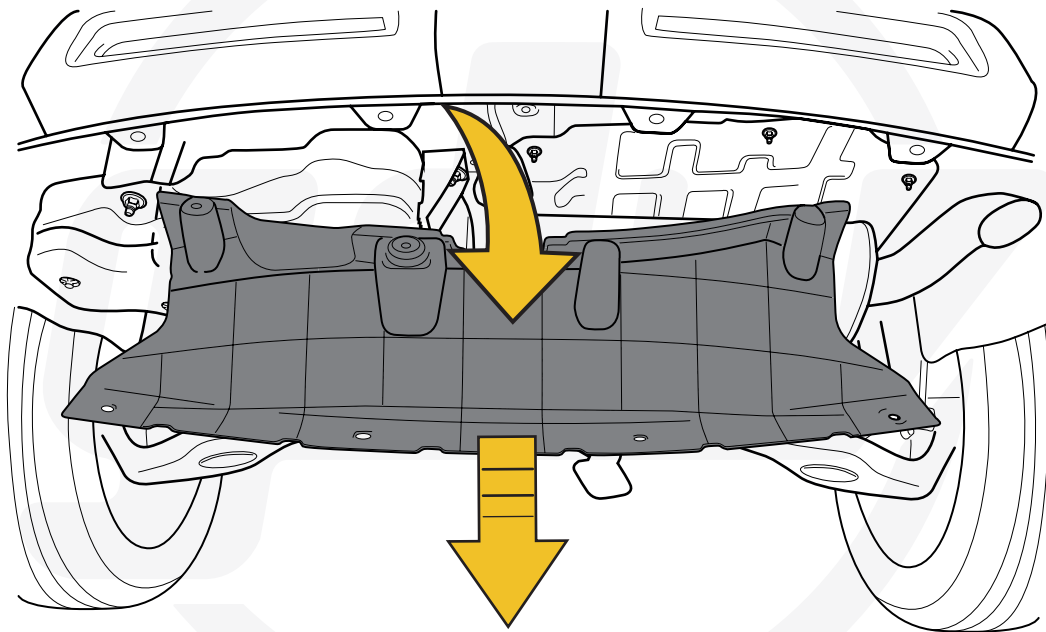

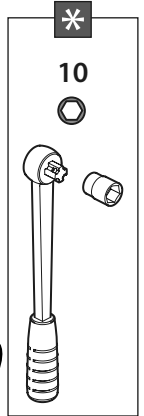
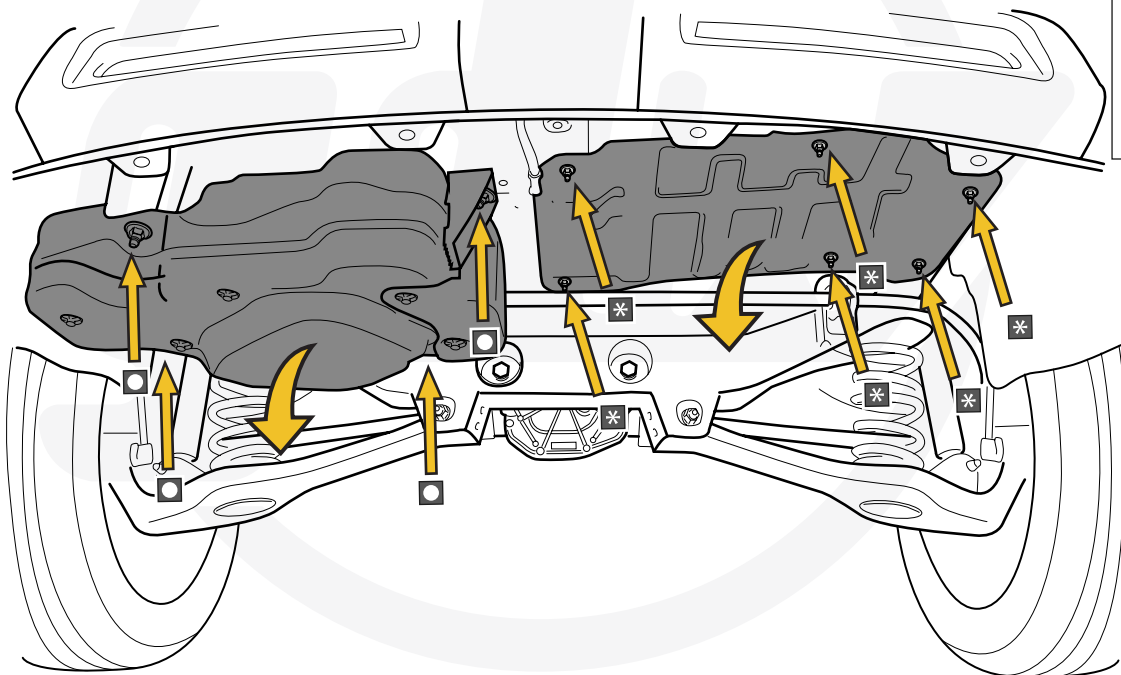
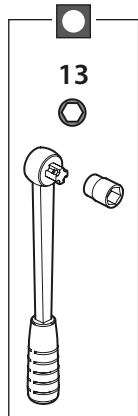
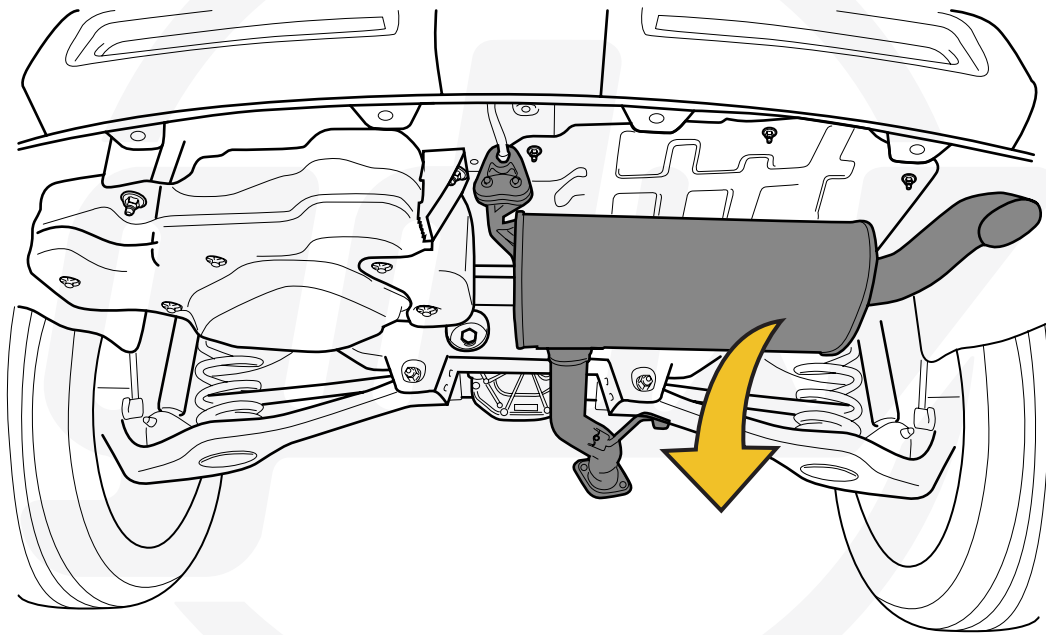

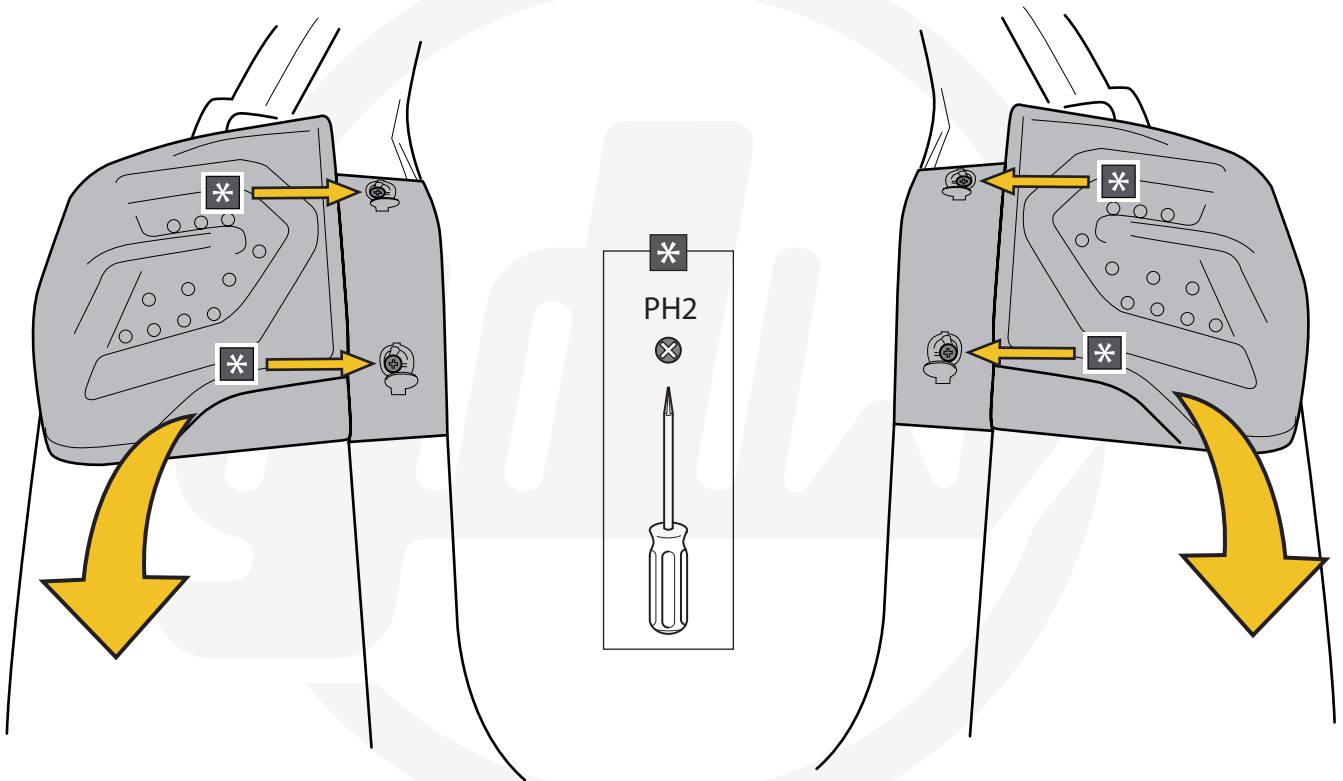
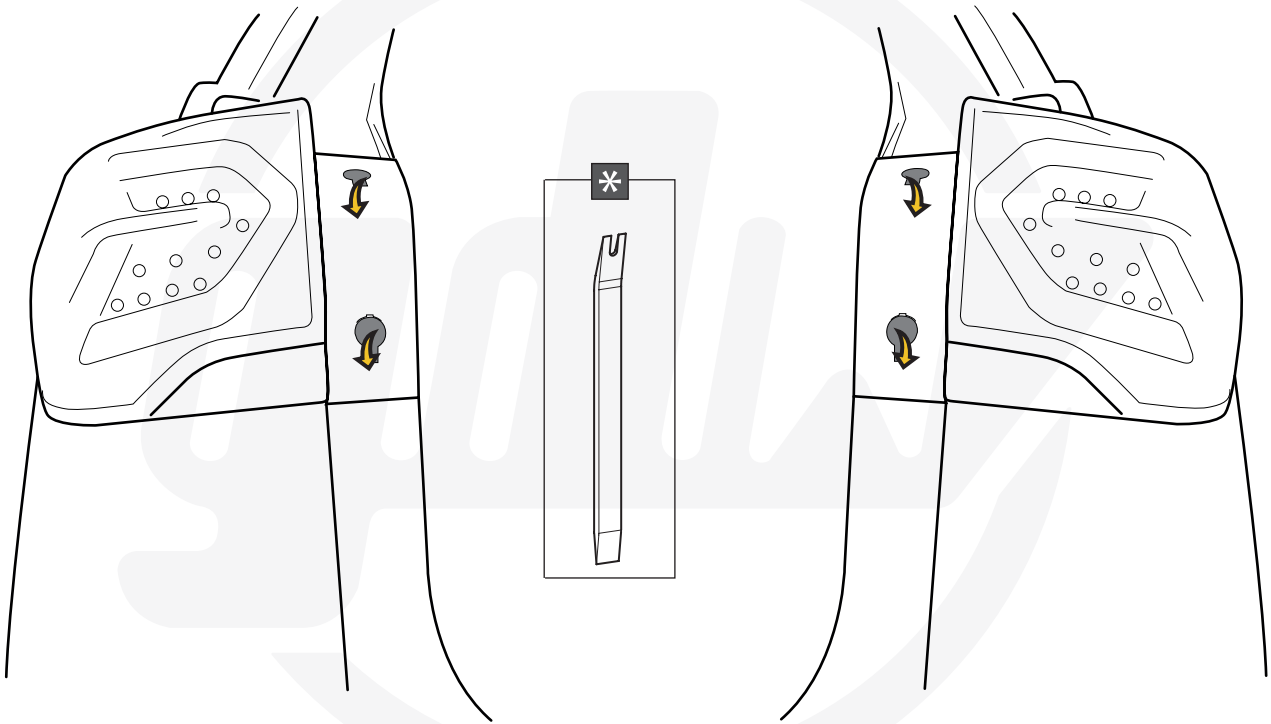

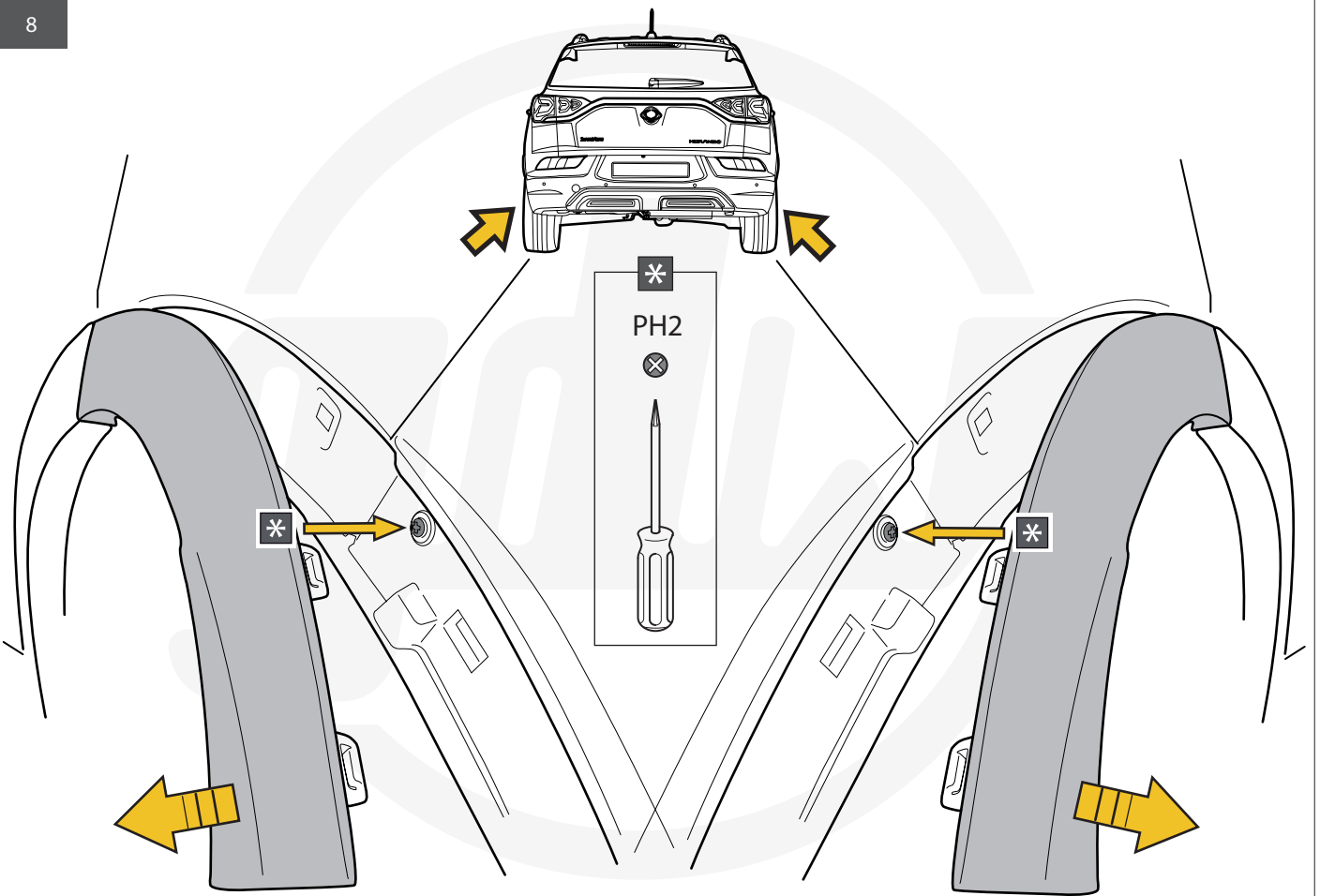
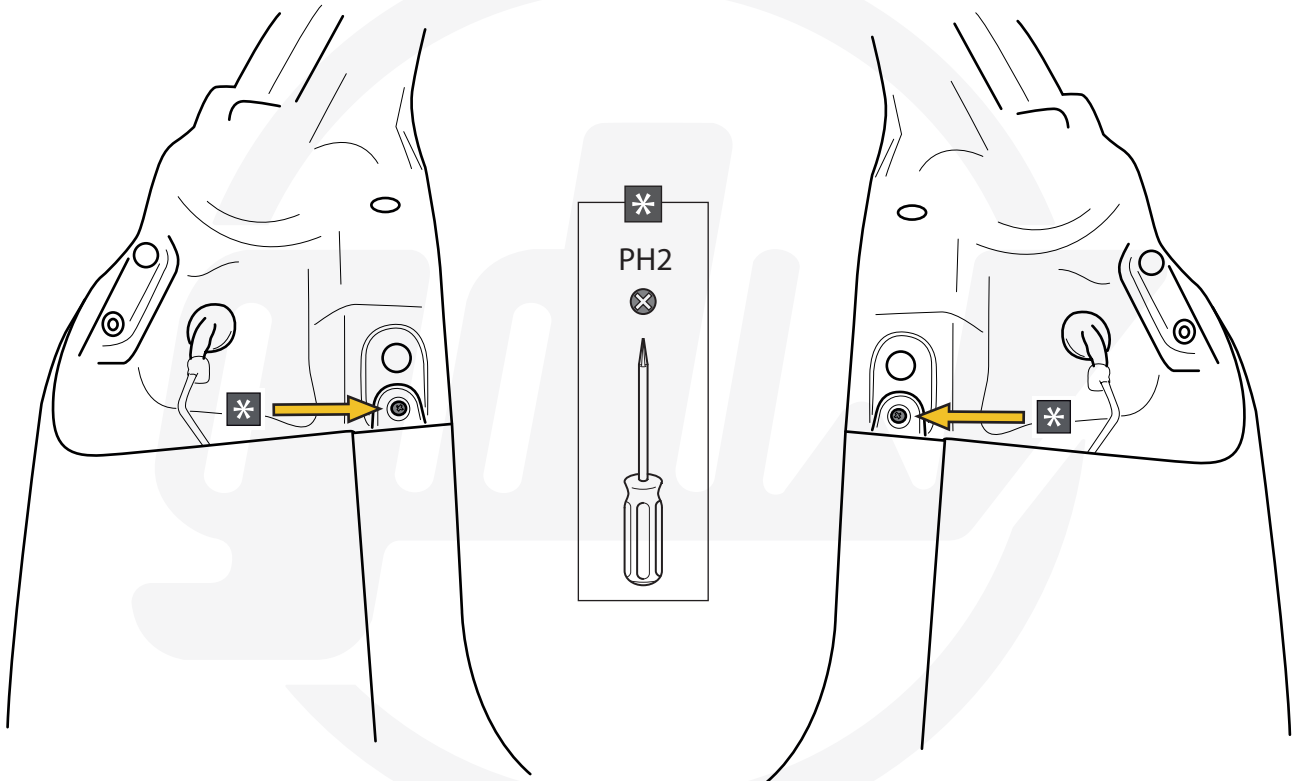

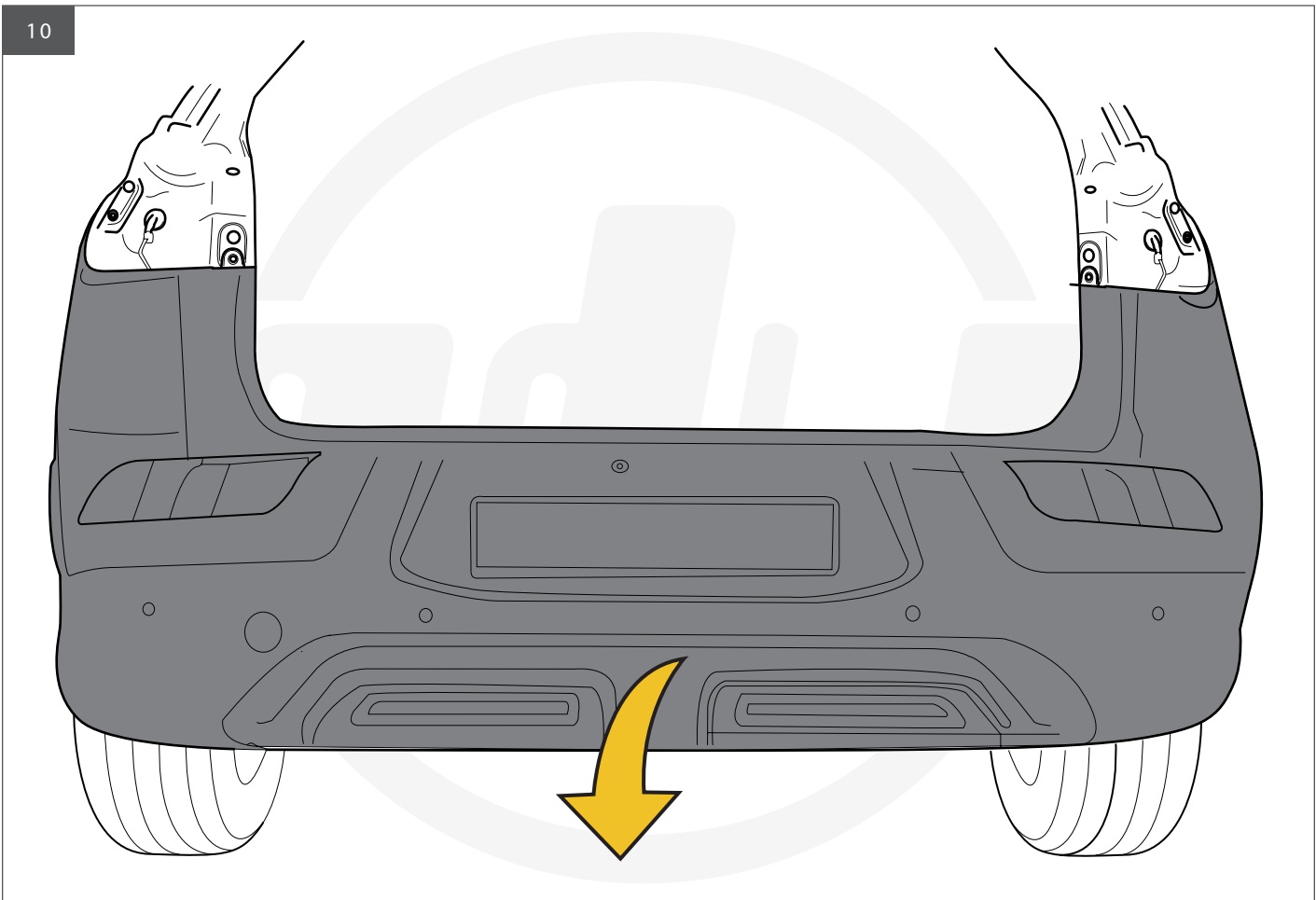
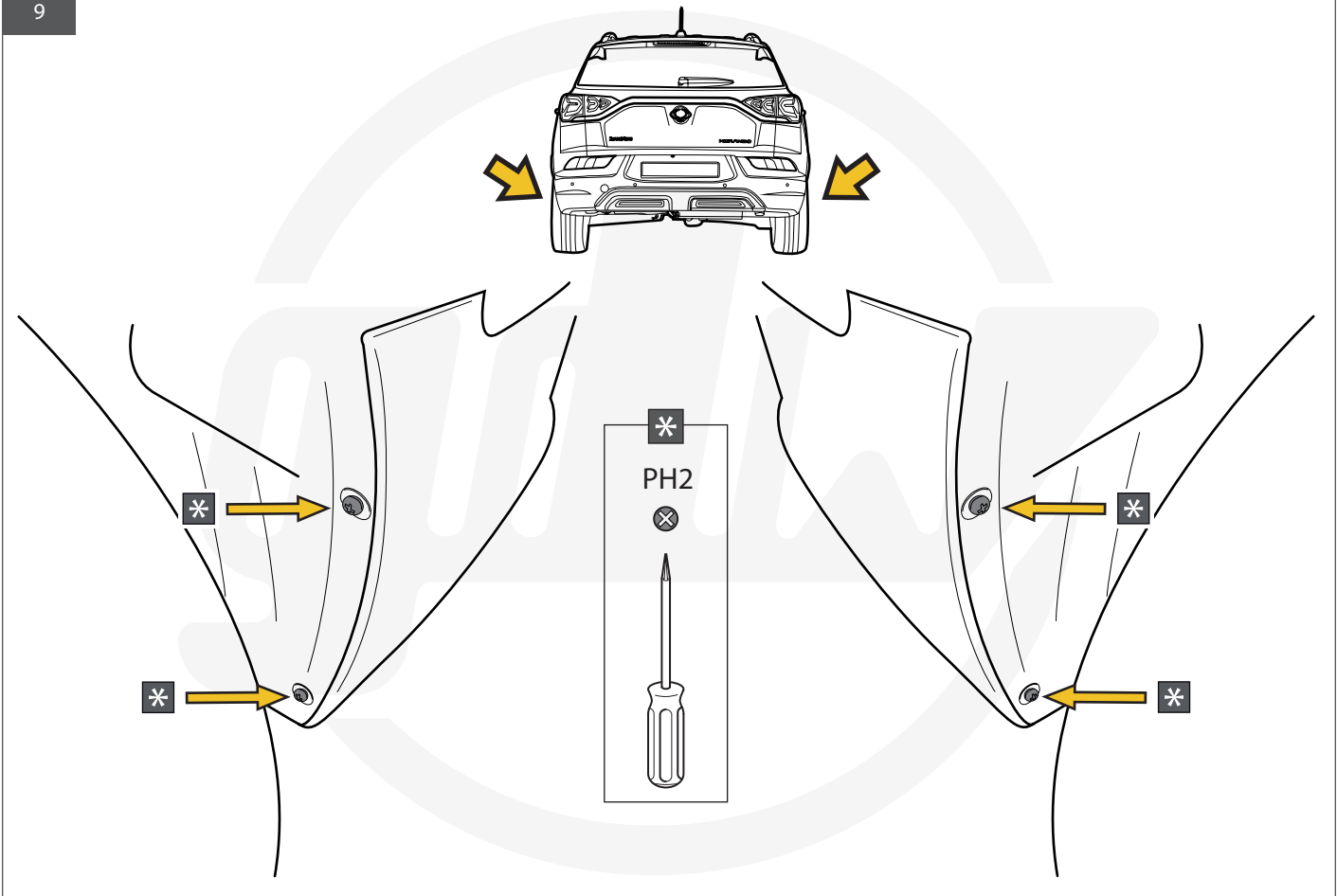

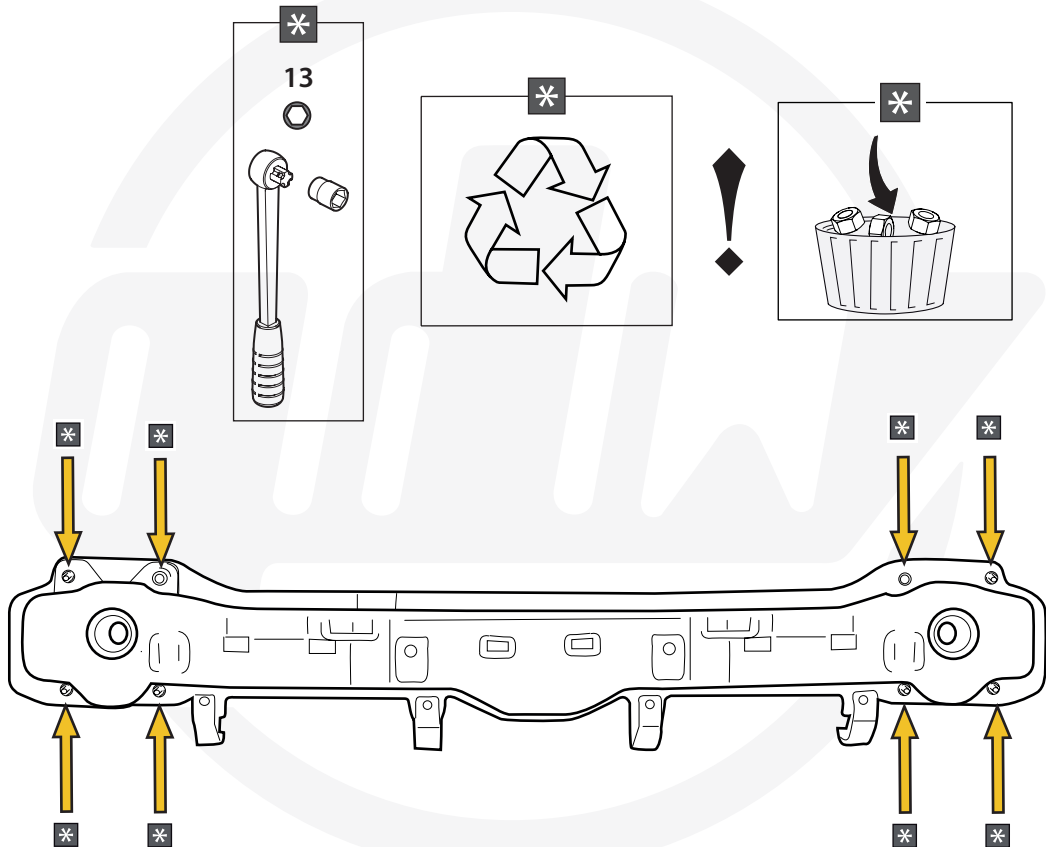
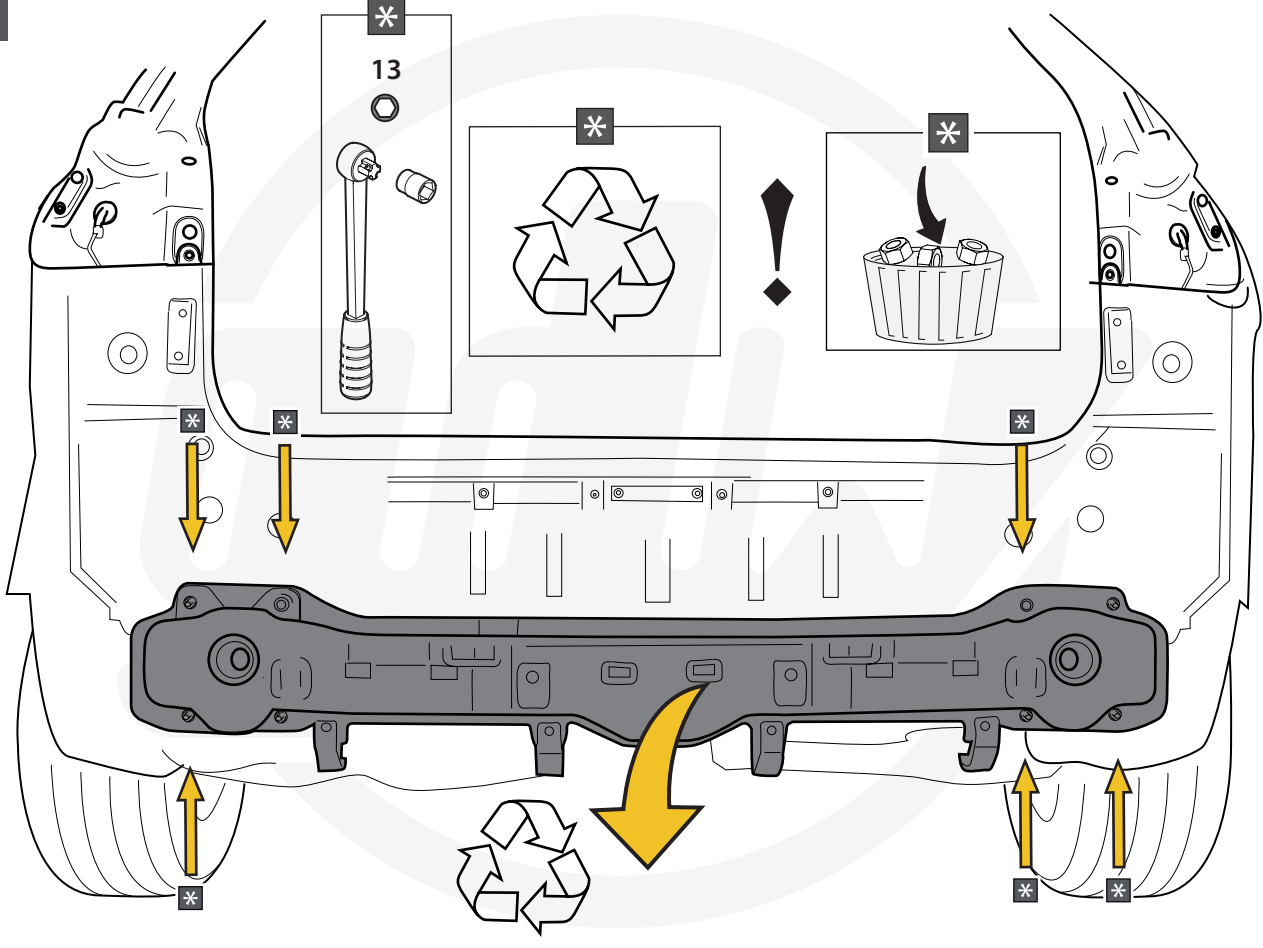

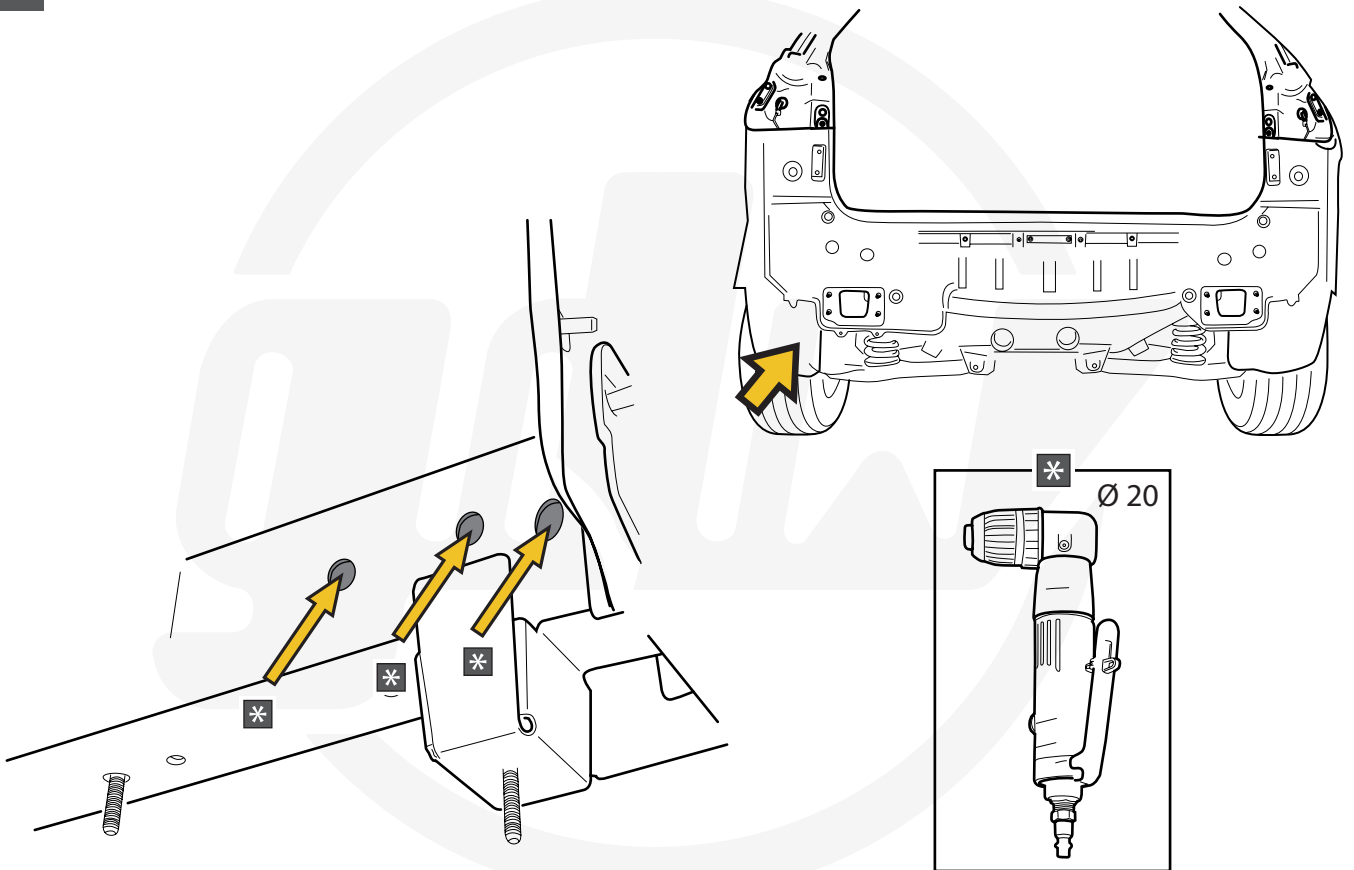
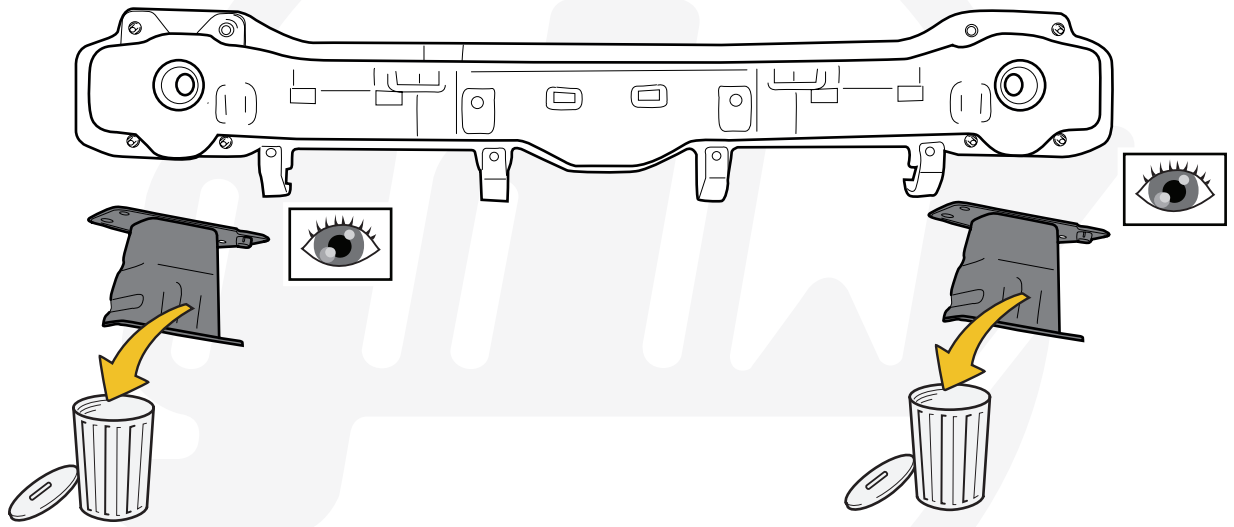

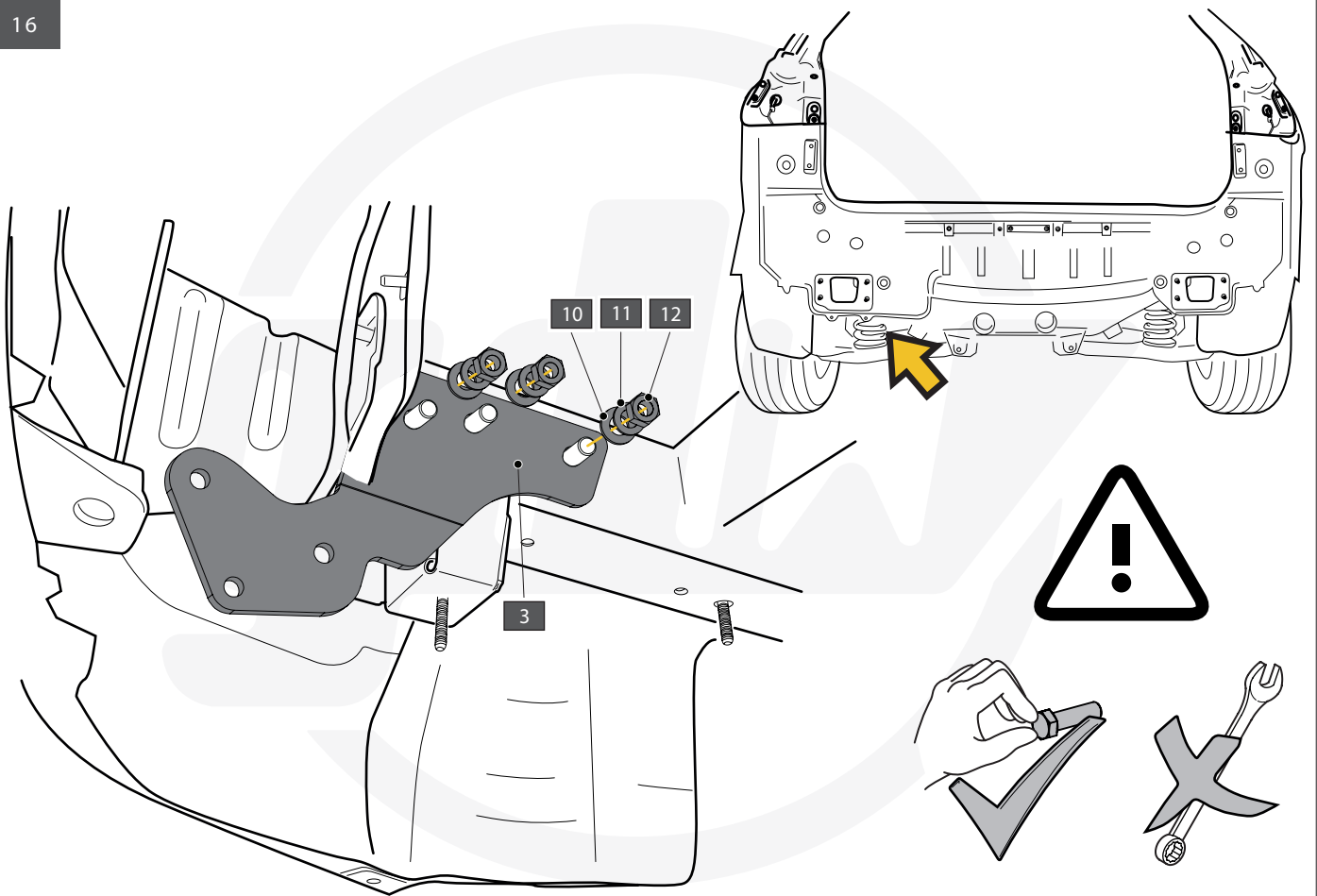
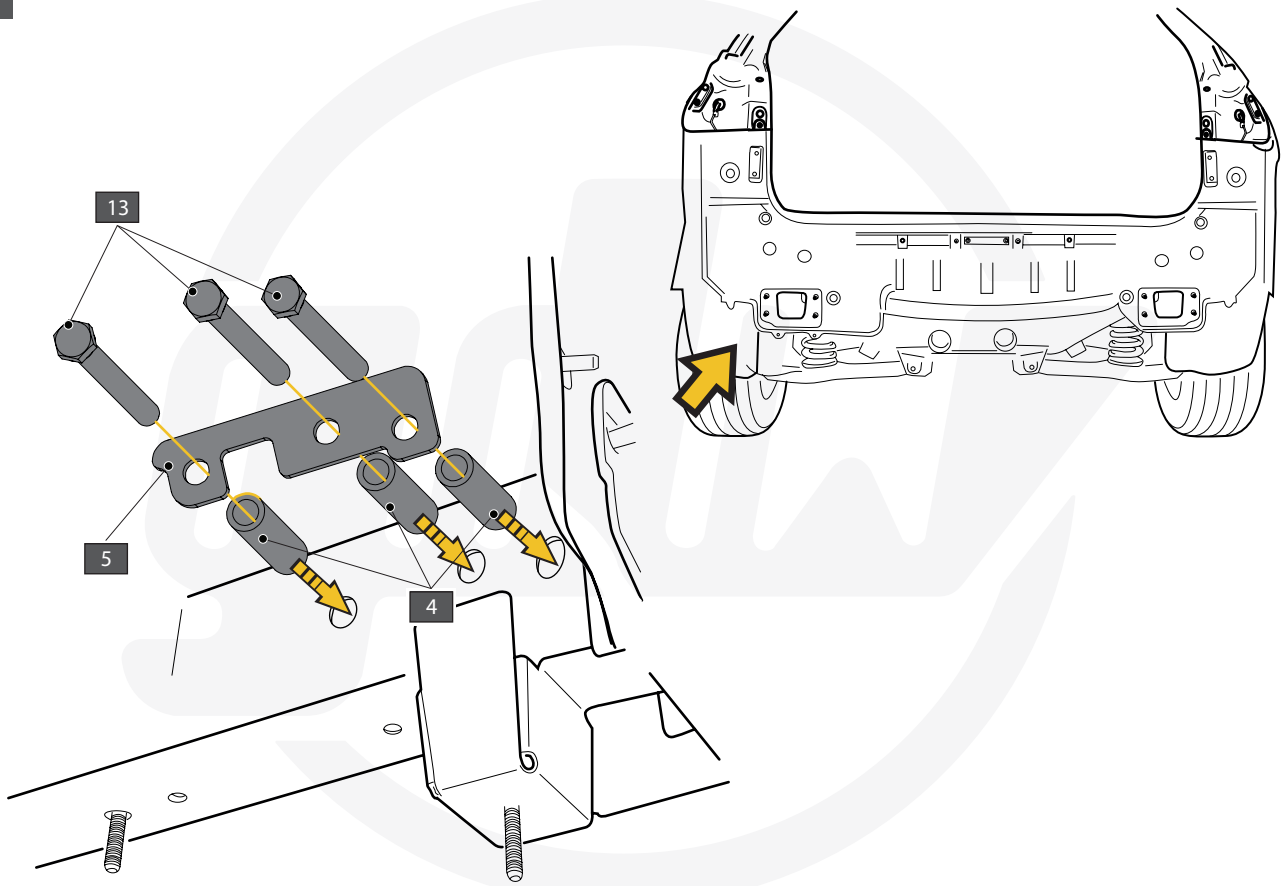

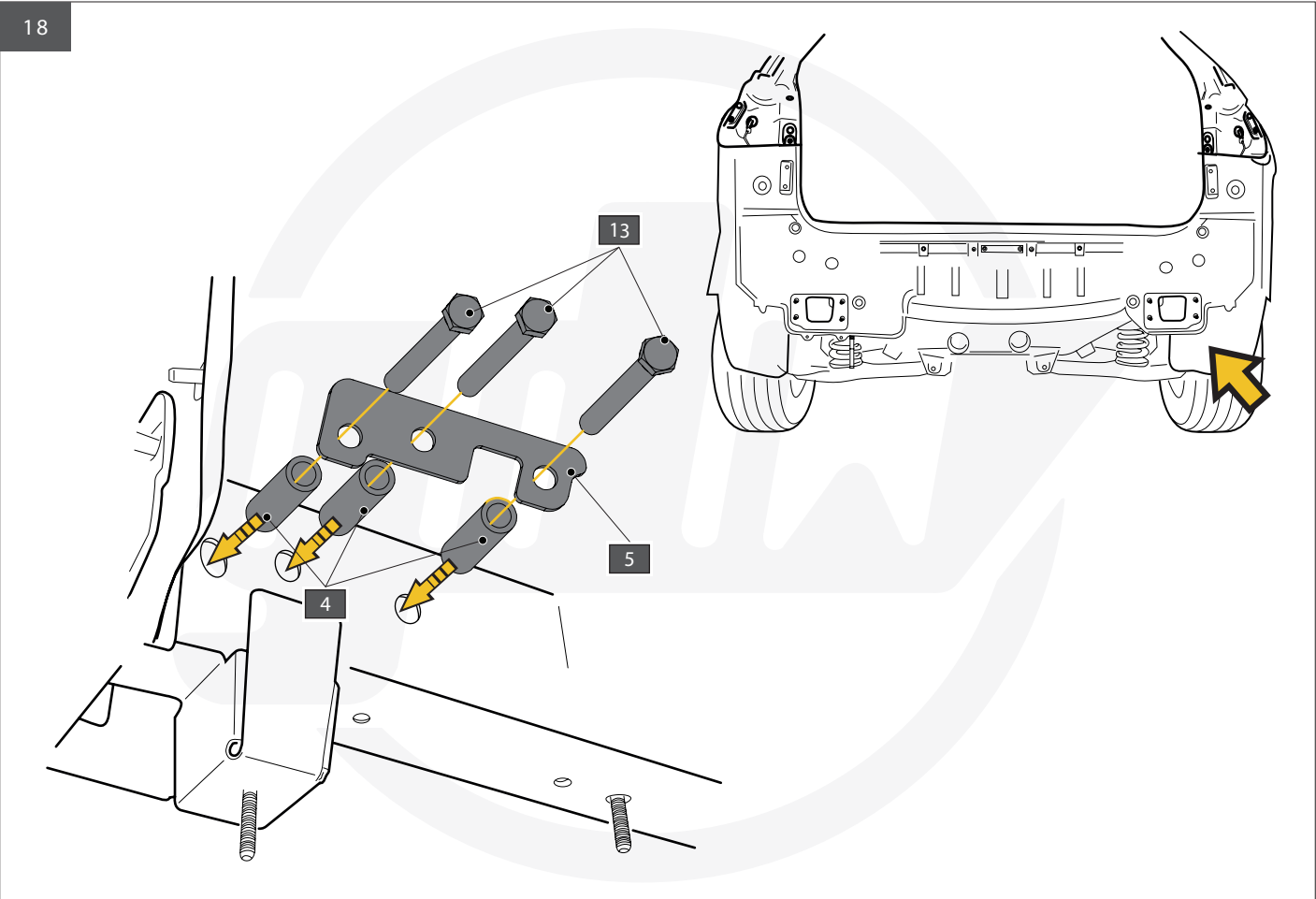
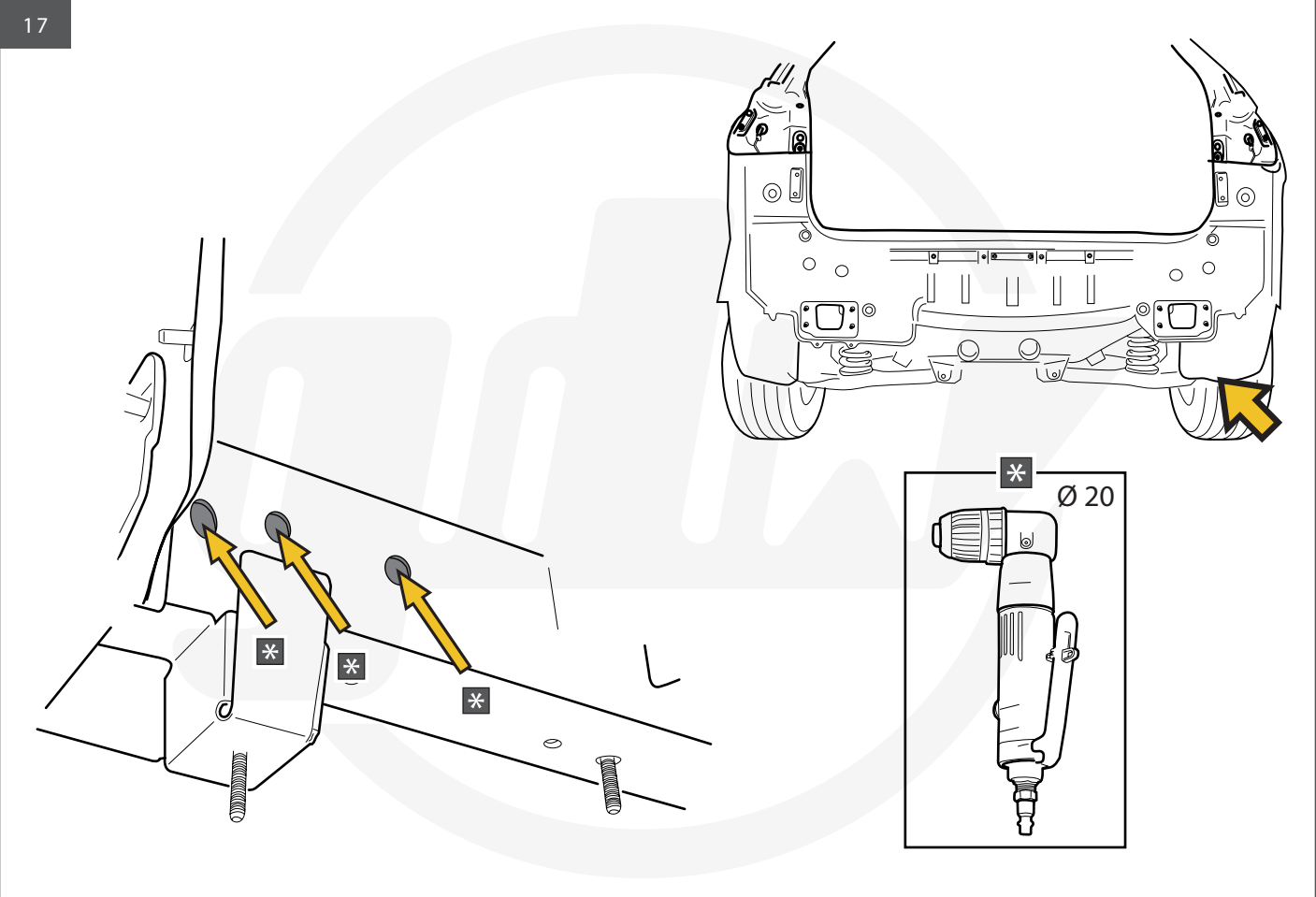

19

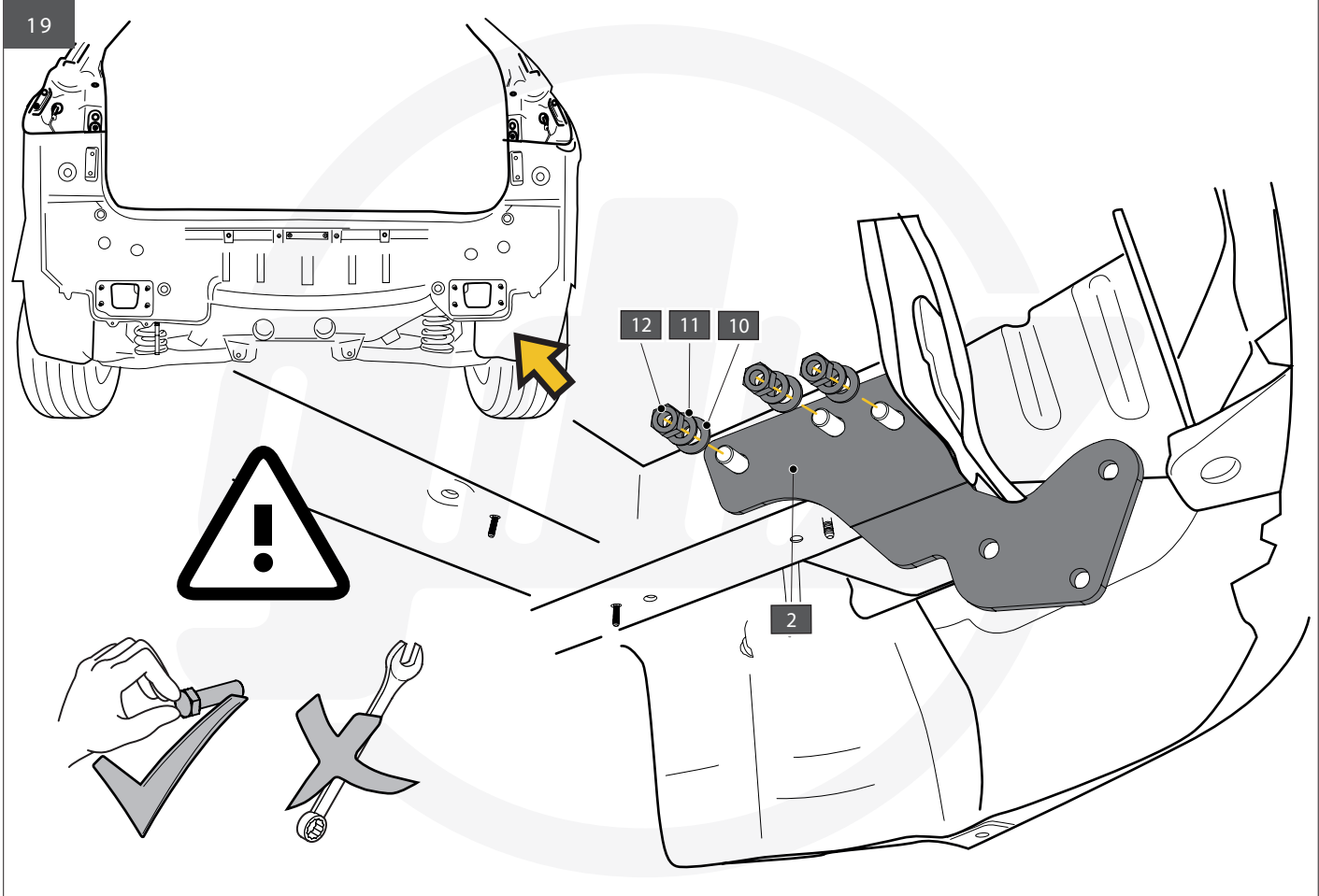

20

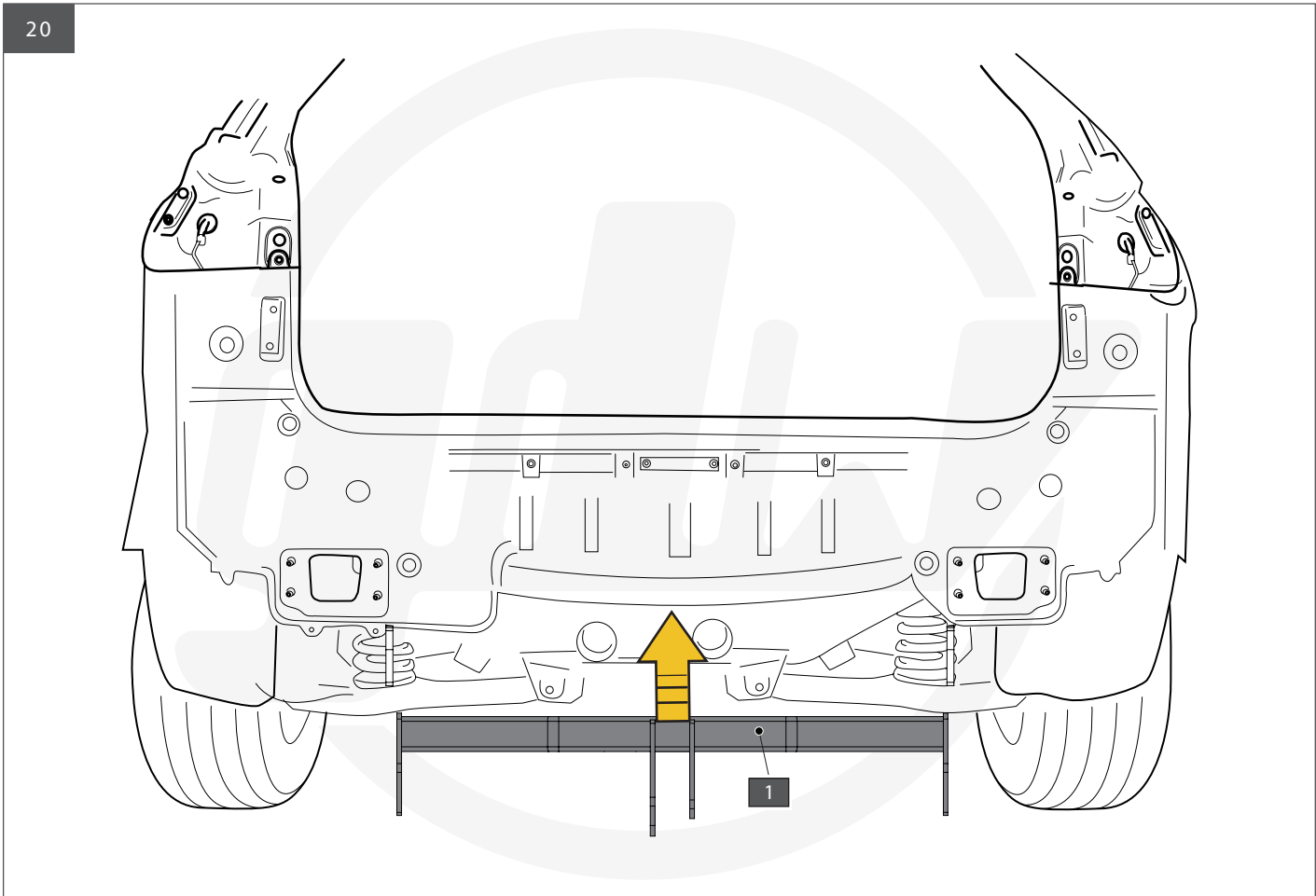

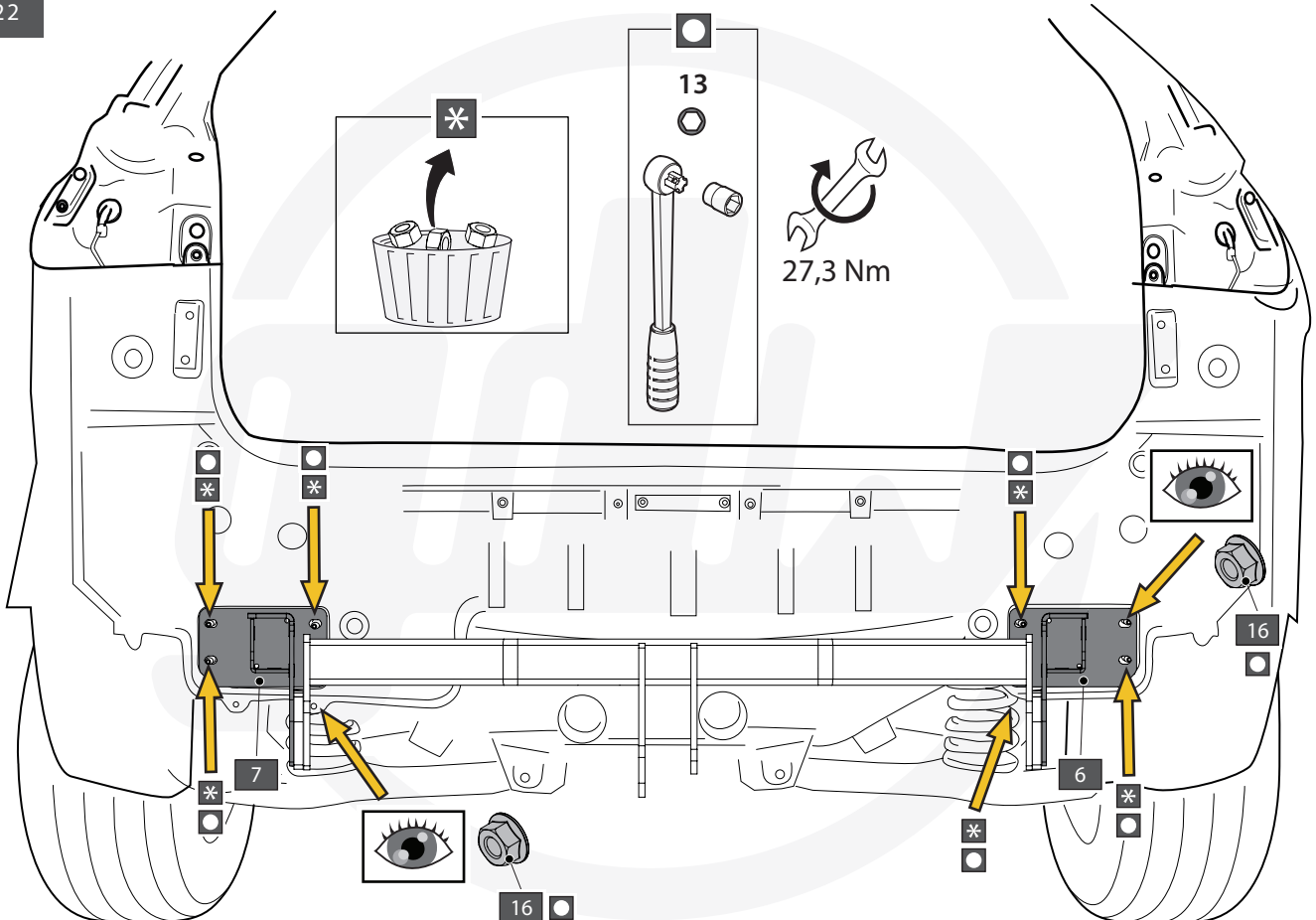
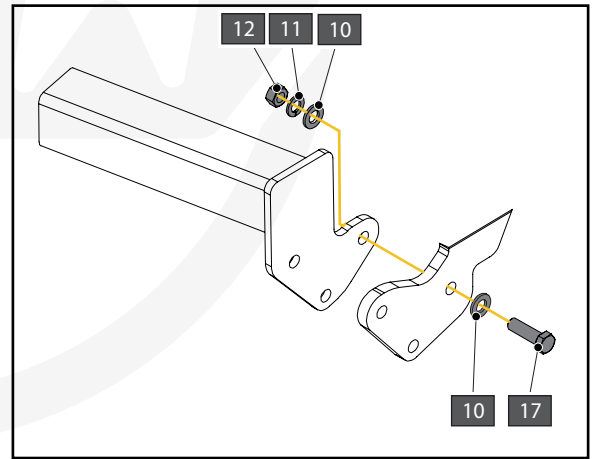
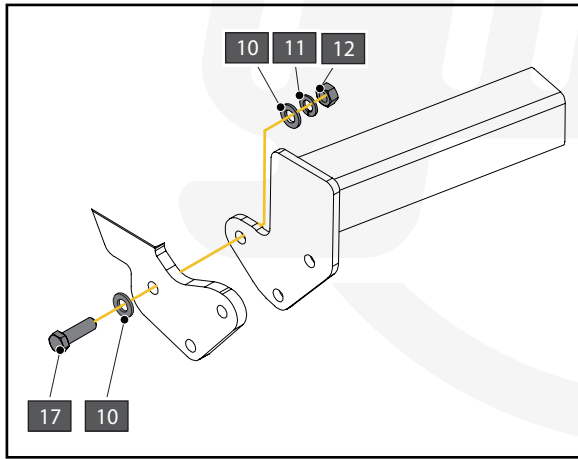
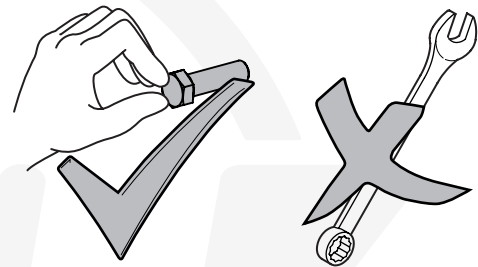
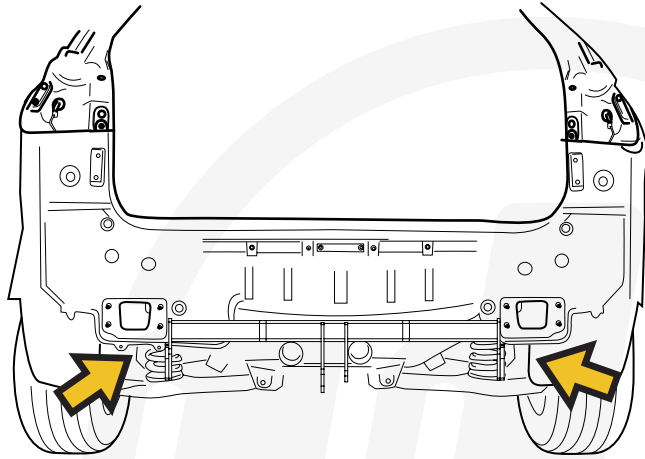

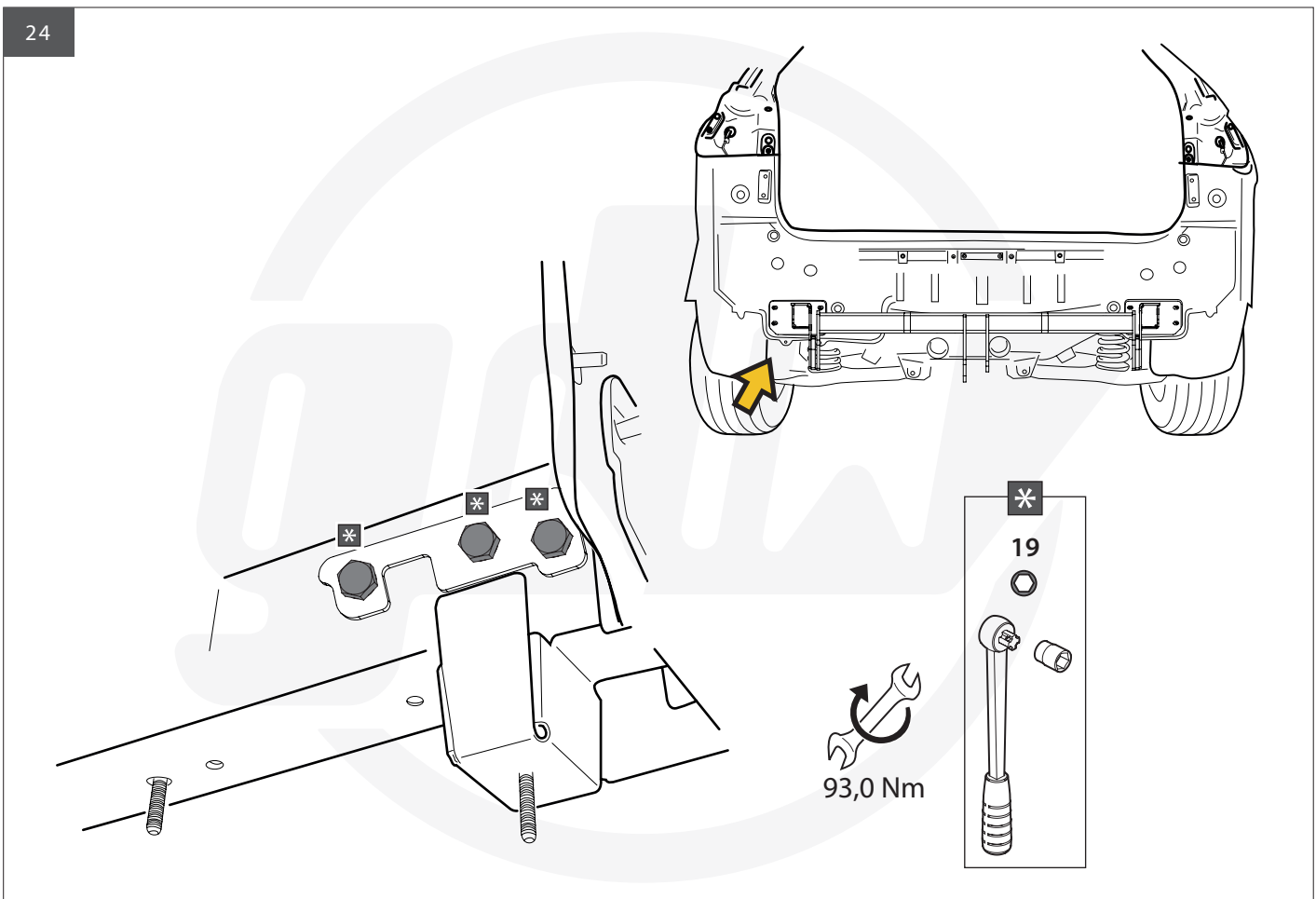
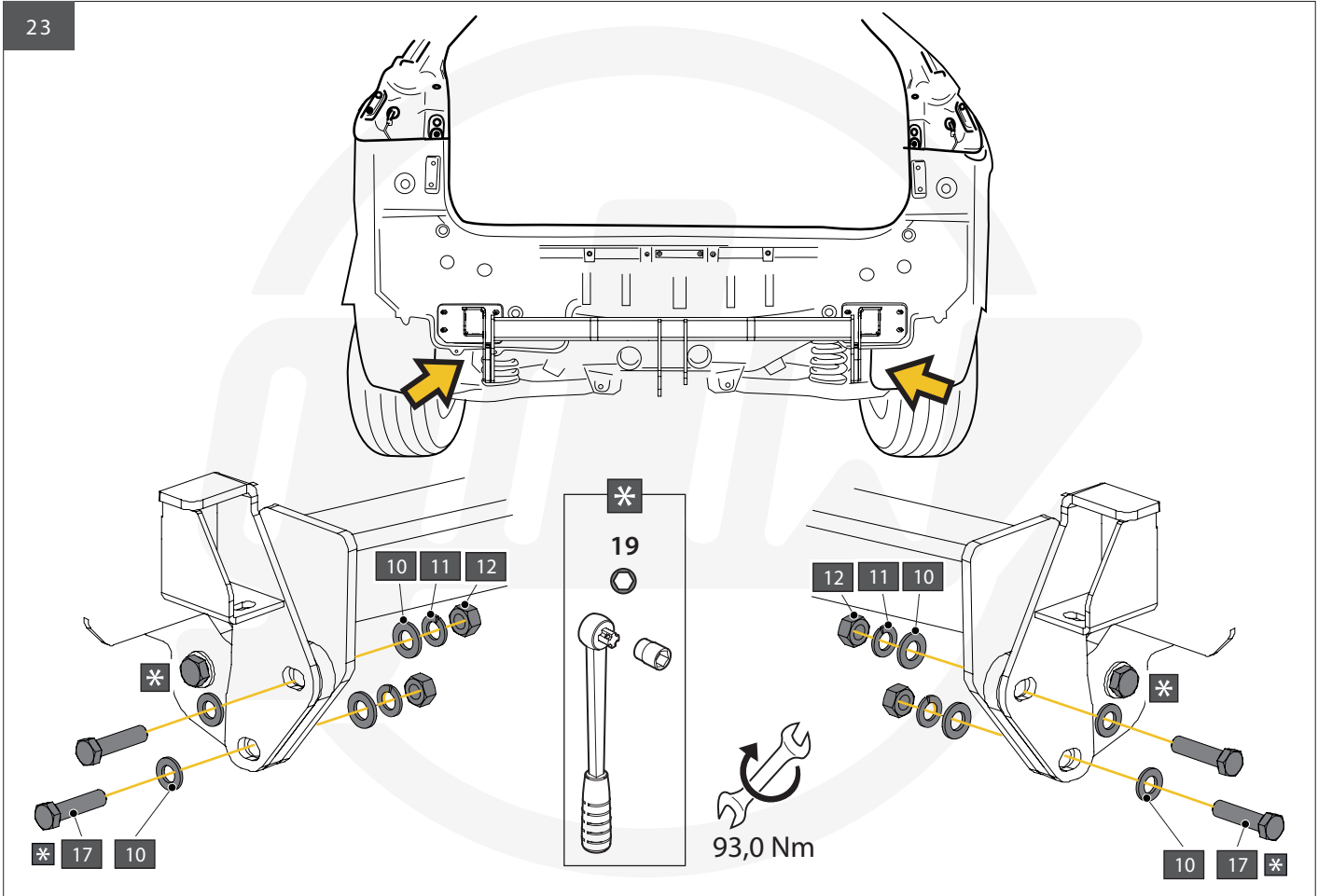

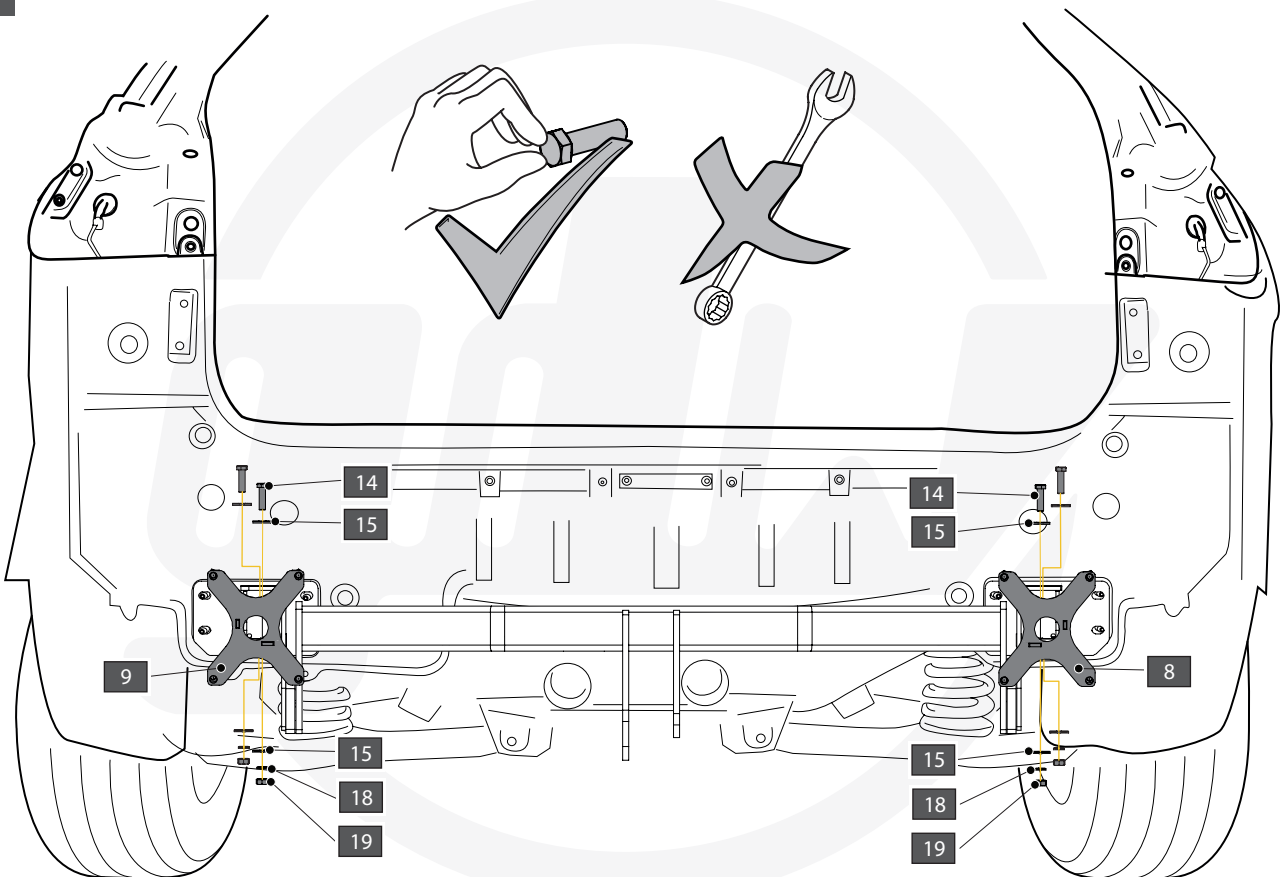
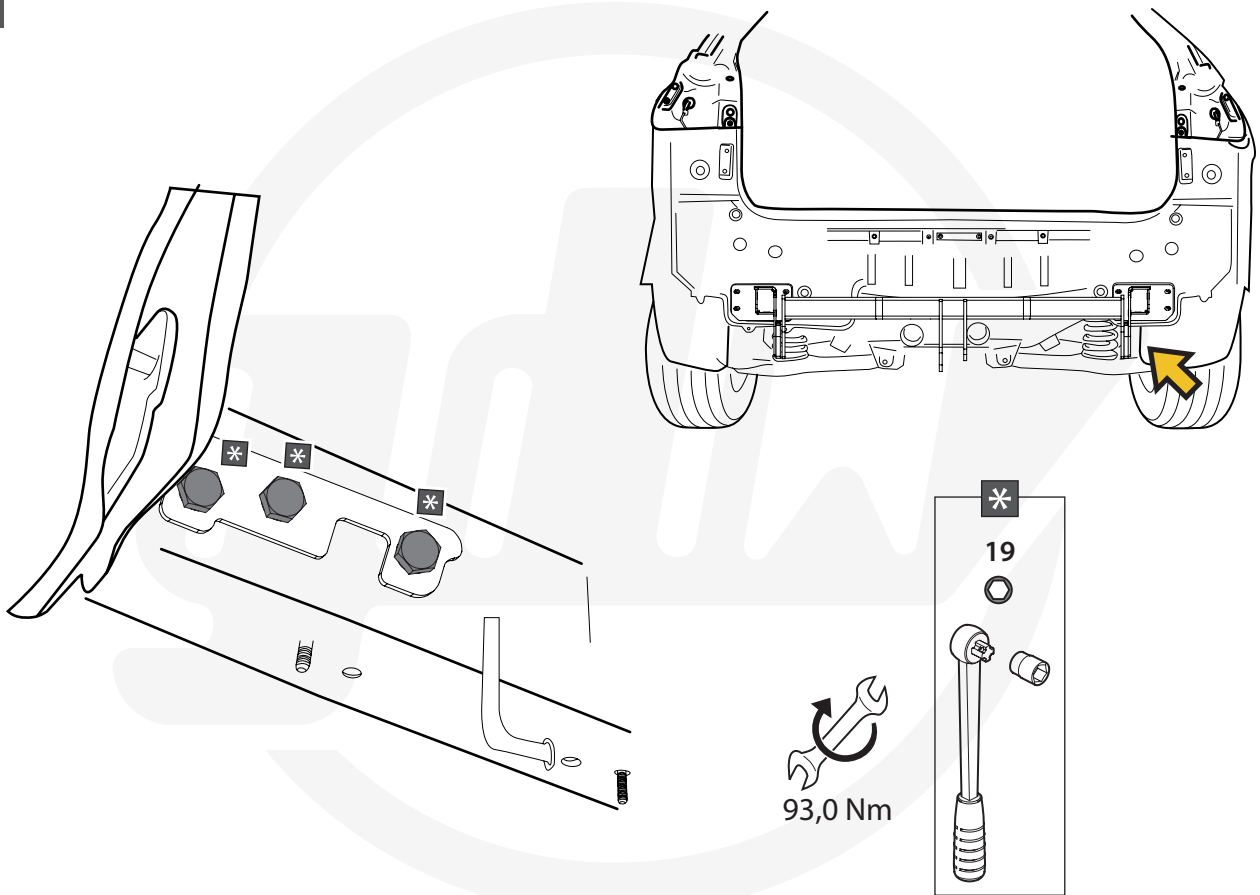

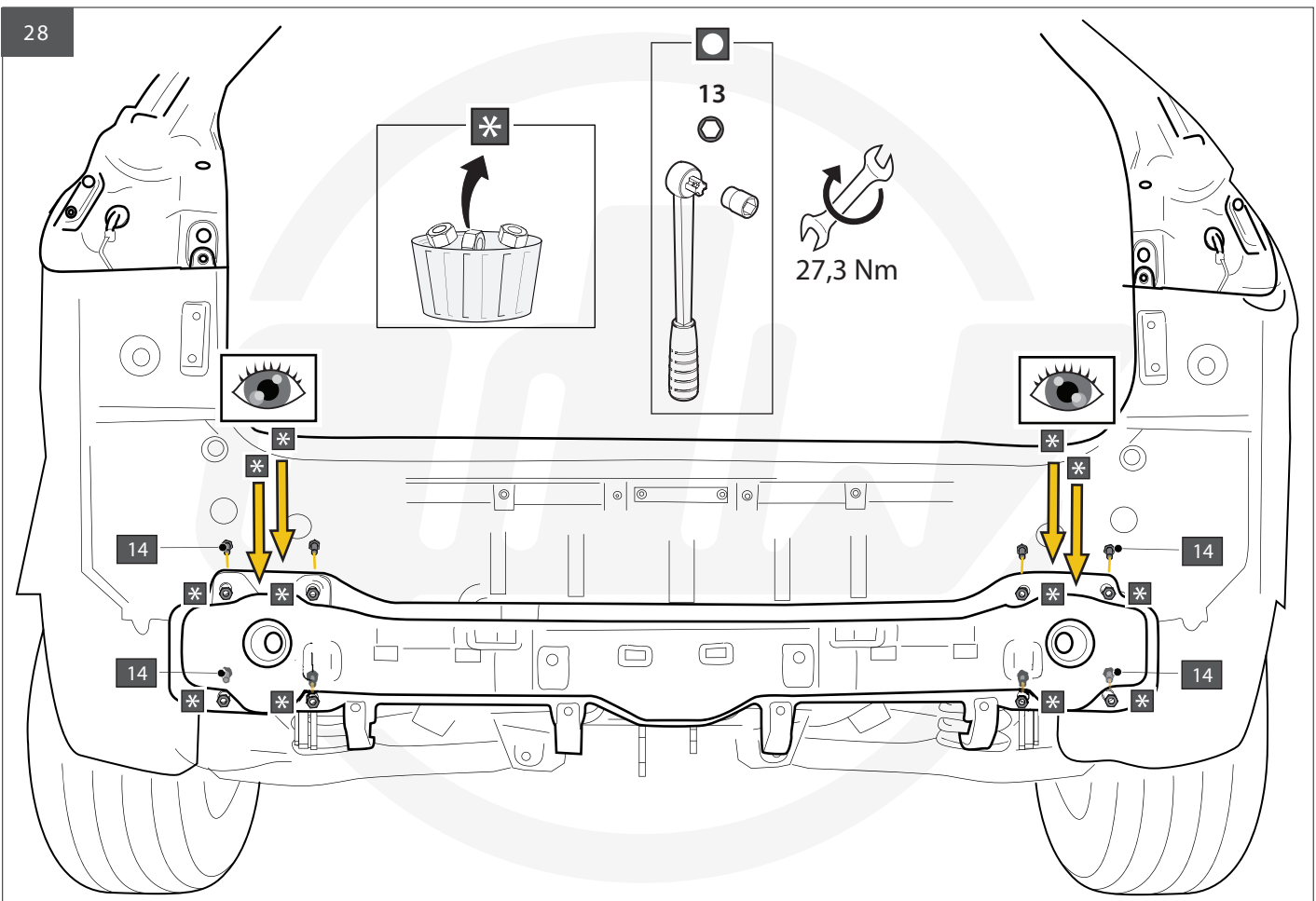
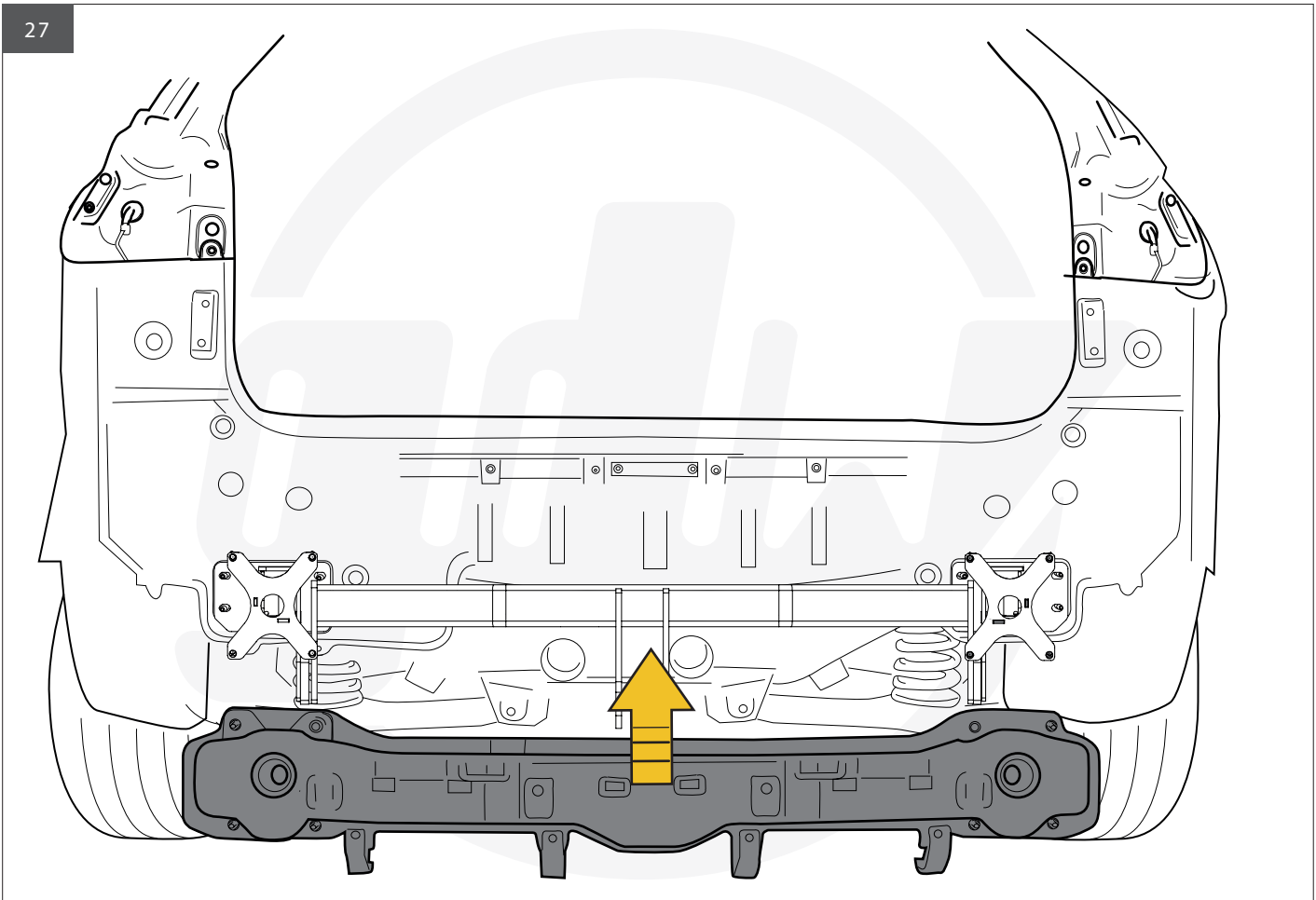

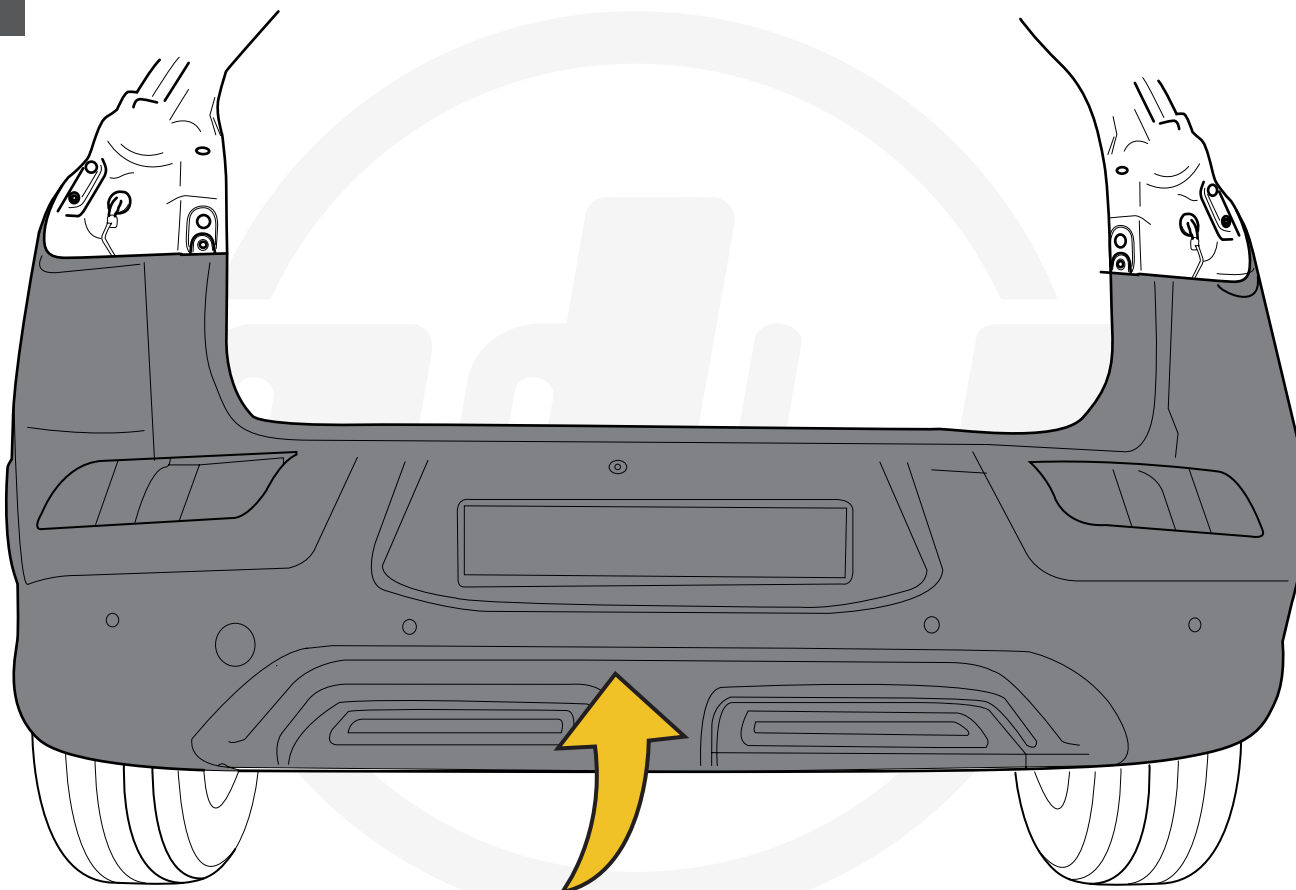
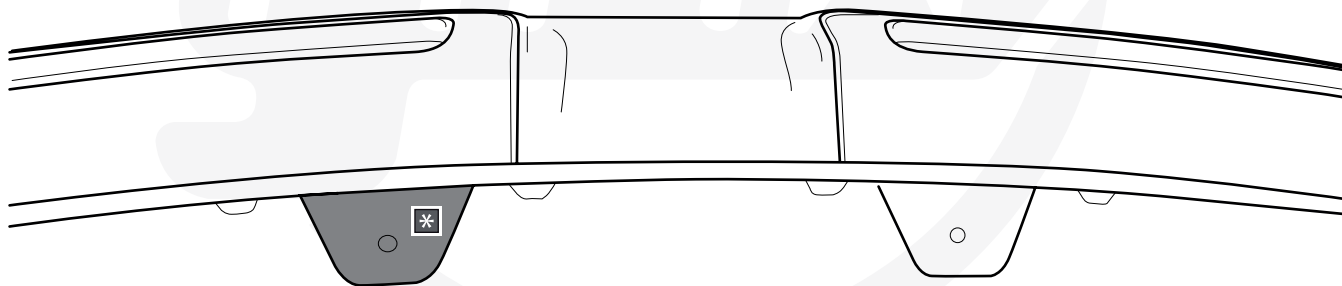
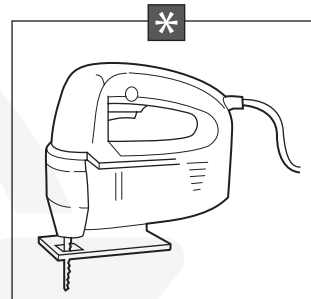
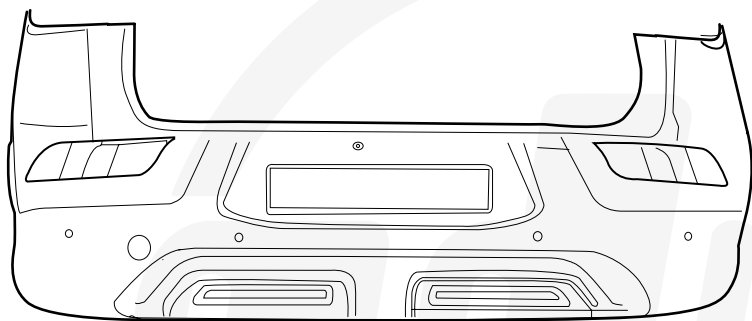

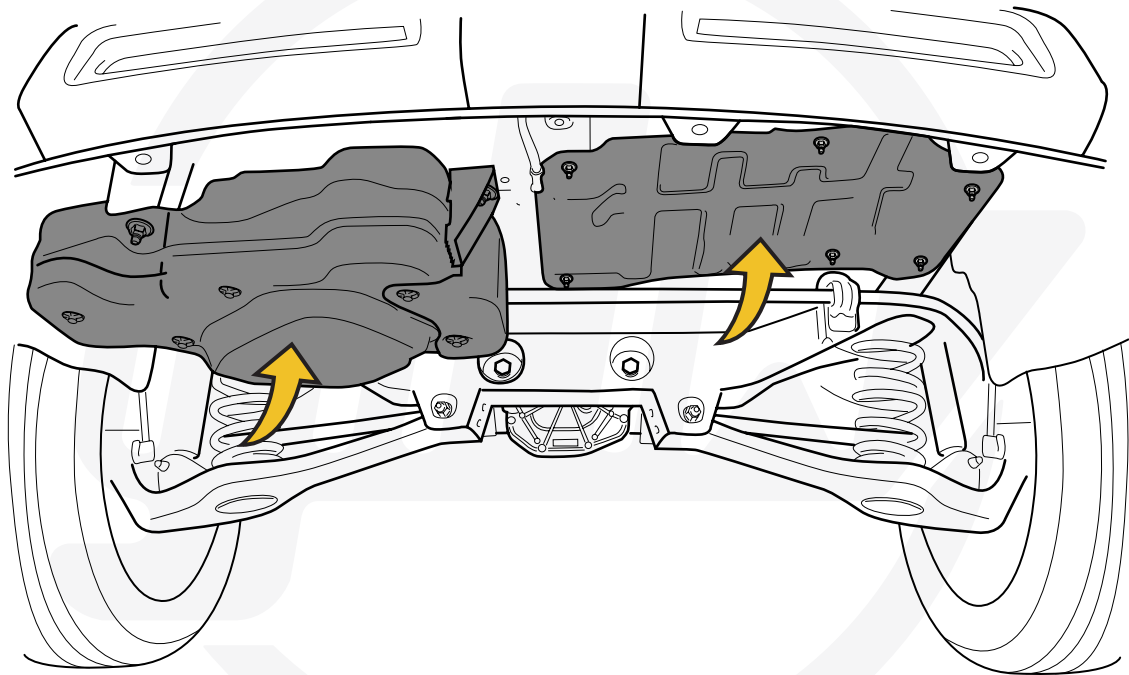
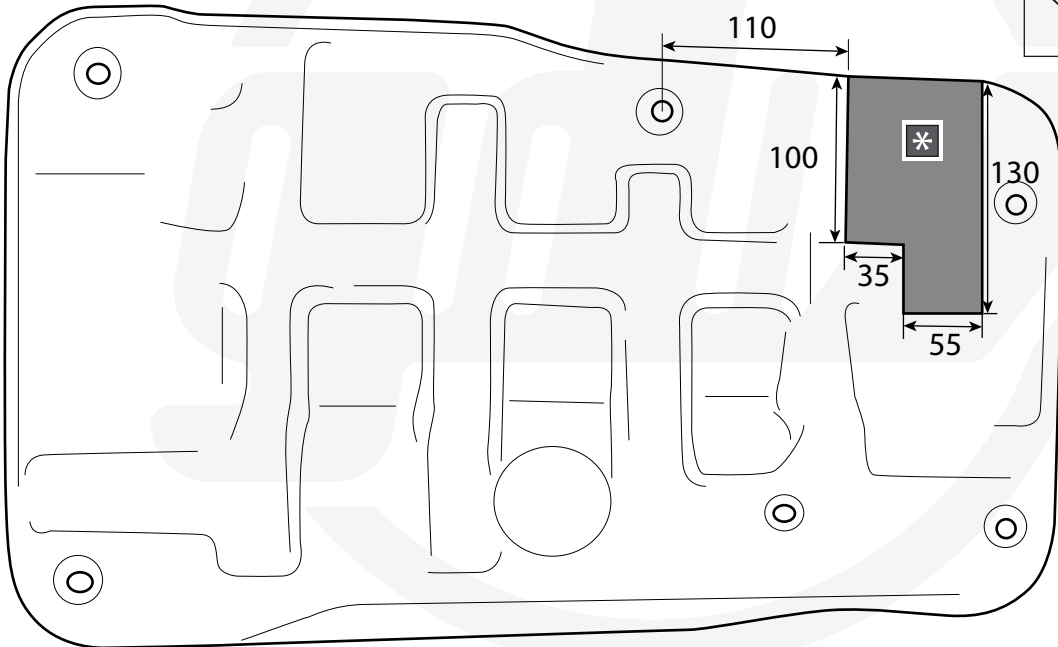
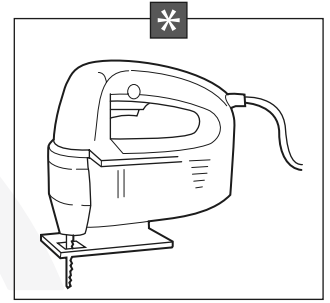

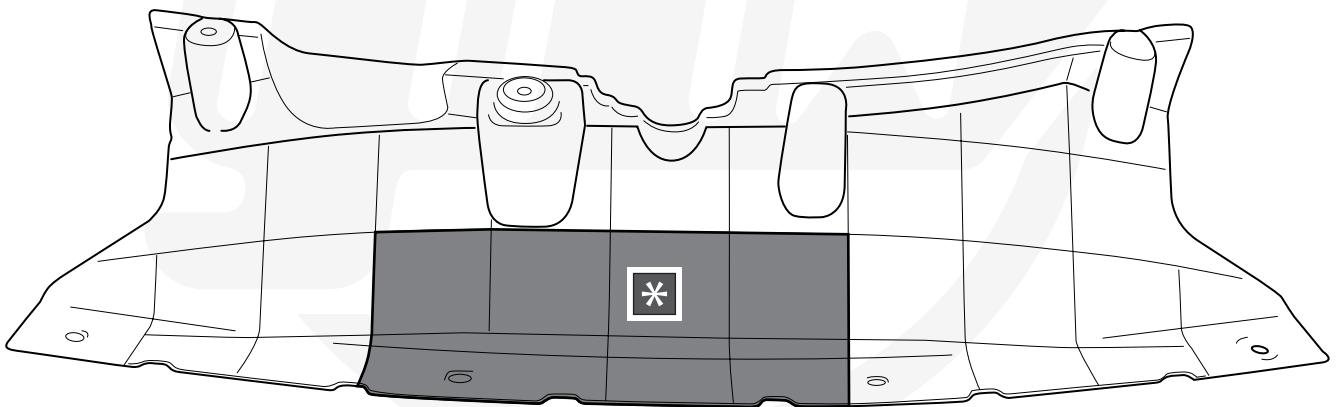
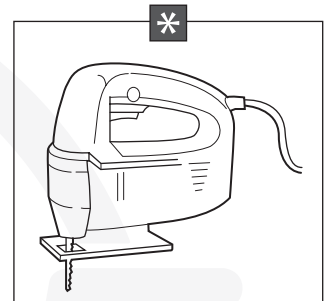
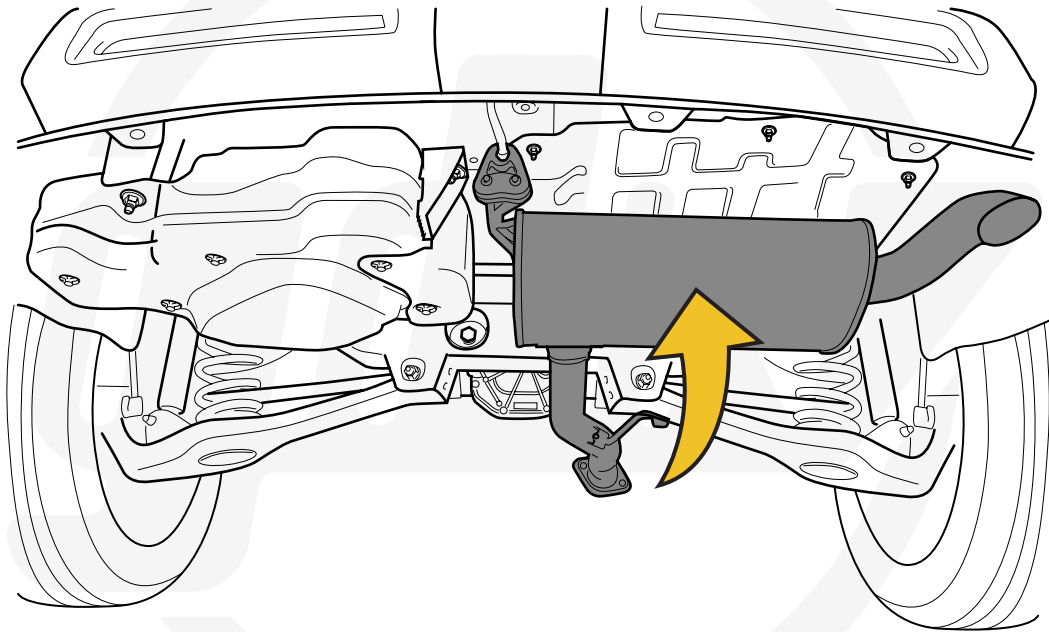

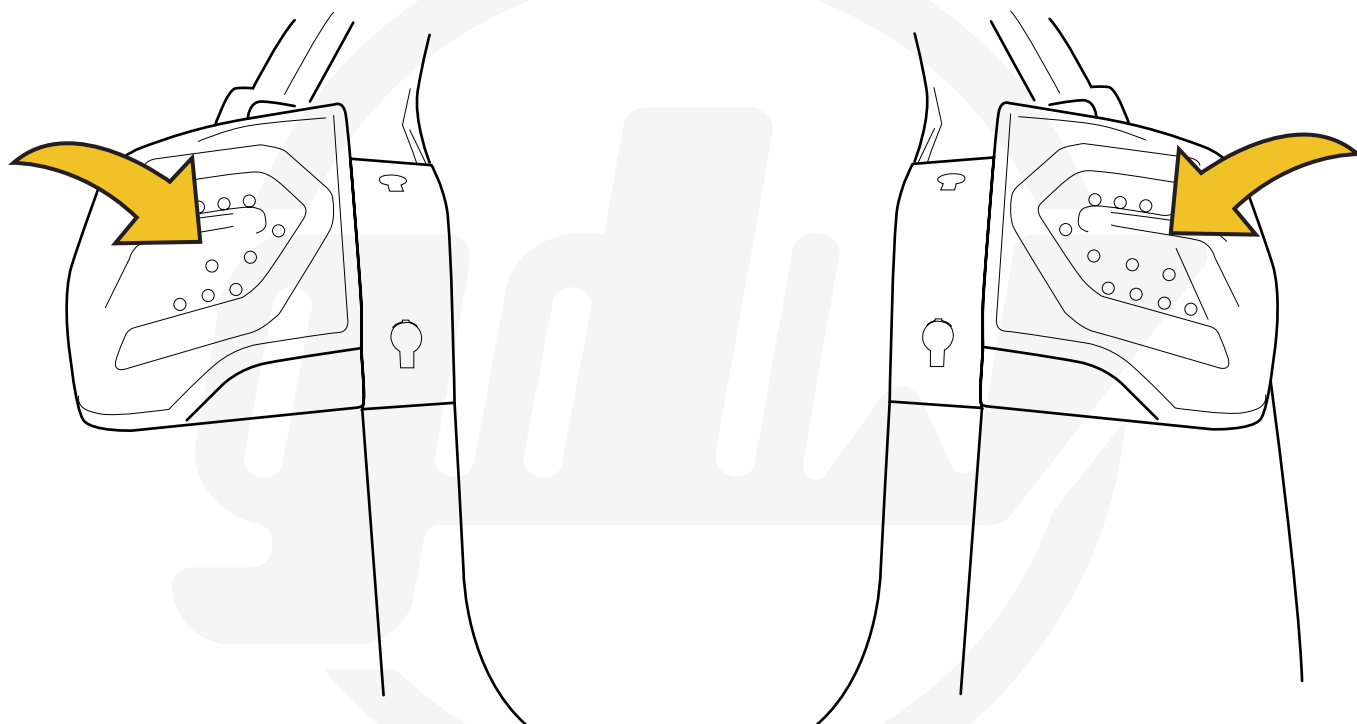
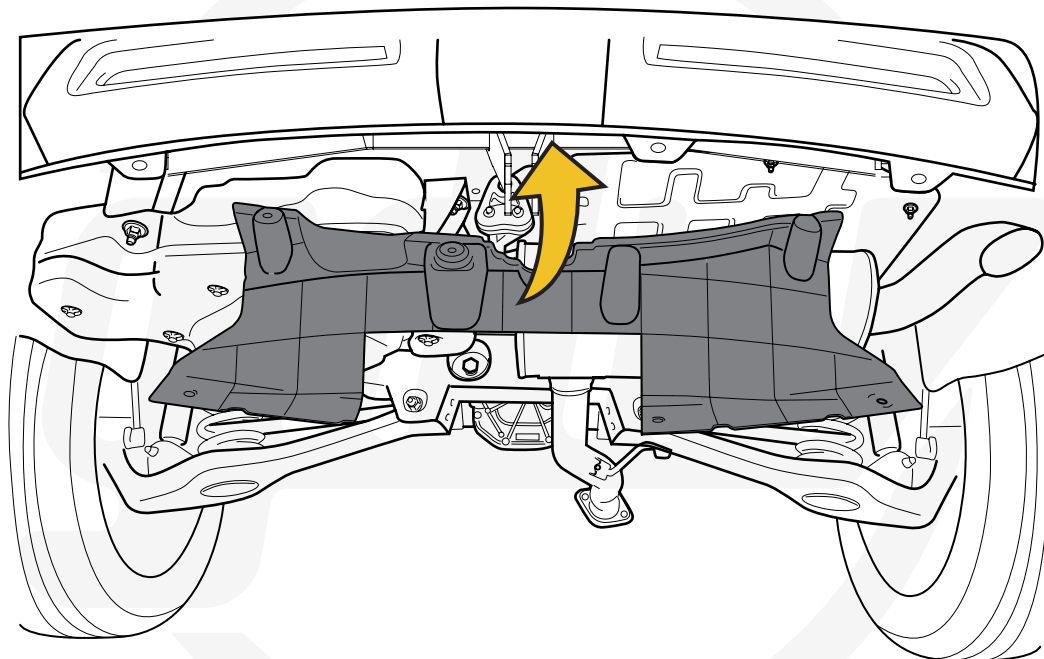

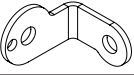



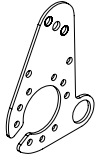



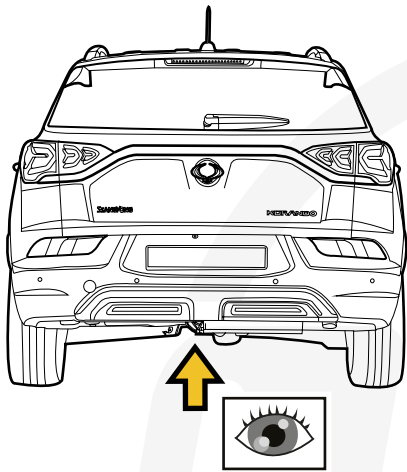
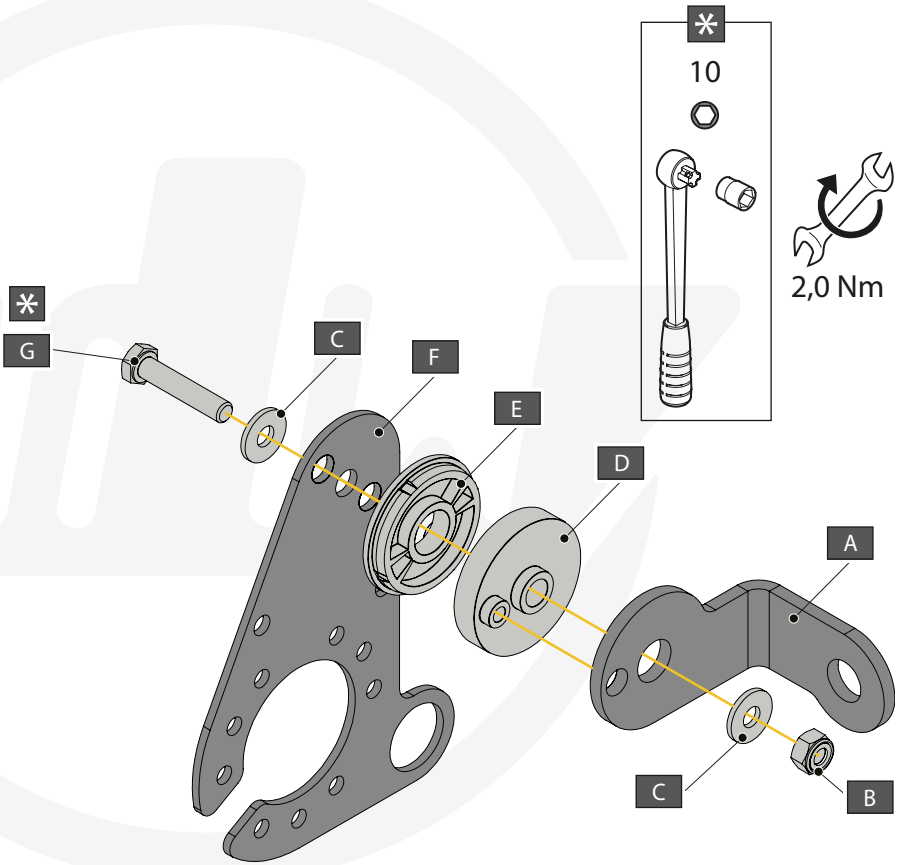

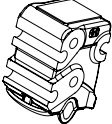
A		X1	GDW REF. 908.095
B		X1	DIN985-M6
C		X2	6,2 X 15,4 X 1,6 (NYLON)
D		X1	GDW REF. 718.16.002
E		X1	GDW REF. 718.16.003
F		X1	GDW REF. 908.094
G		X1	DIN933-M6 X 30



A		X1	912.003
B		X3	DIN931-M12X110
C		X6	DIN125A-M12
D		X3	DIN128A-M12
E		X3	DIN934-M12

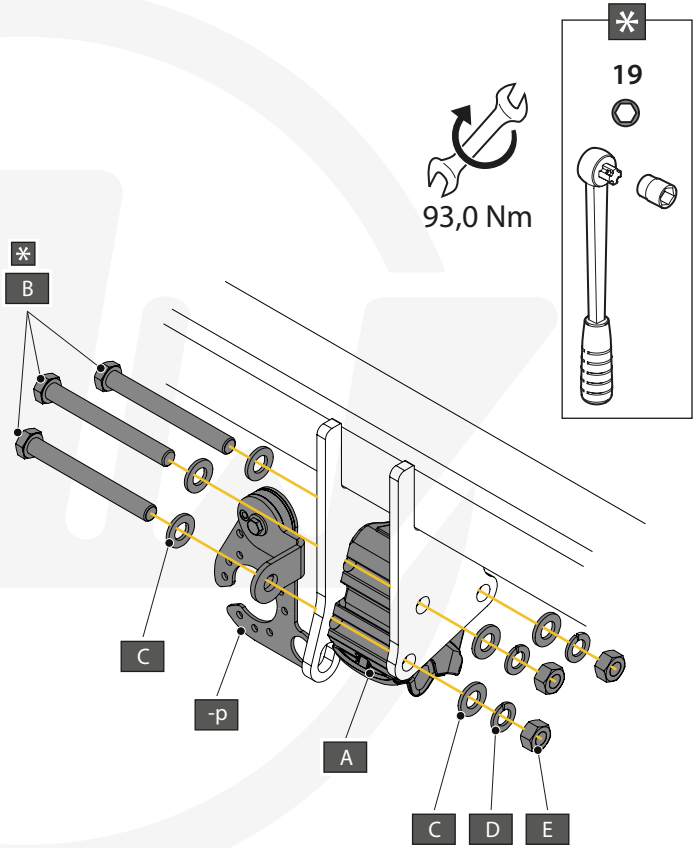

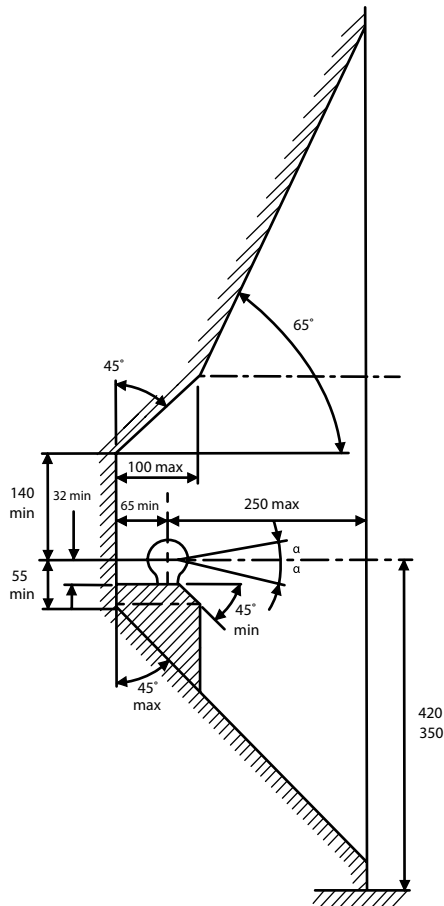

De tussenruimte conform bijlage VII, afbeelding 25 (a,b) van het reglement nr. 55 moet in acht worden genomen.

La zone de dégagement doit être garantie conformément à l'annexe VII, illustration 25 (a,b) de la règle nr. 55.

The clearance specified in appendix VII, diagram 25 (a,b) of regulation nr. 55 must be guaranteed.

Der Freiraum nach Anhang VII, Abbildung 25 (a,b) der Regulierung nr. 55 ist zu gewährleisten.

Revisar la imagen 25 (a,b) del suplemento VII según la regulación nr. 55.

Frirummet skal overholdes iht. bilag VII, fig. 25(a,b) i regulering nr. 55.

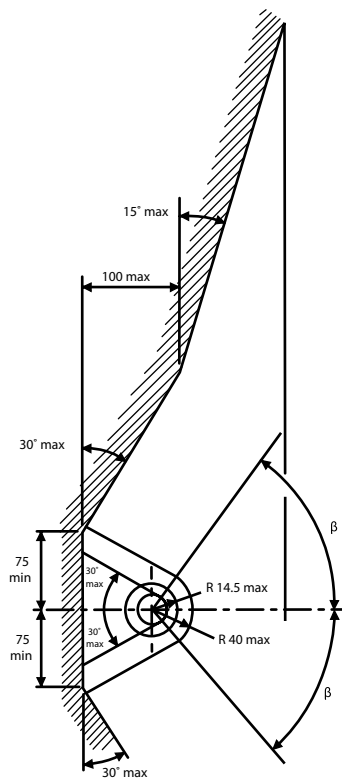

Bij toelaatbaar totaal gewicht van het voertuig

Pour poids total en charge autorisé du véhicule

At laden weight of the vehicle

Bei zulässigem Gesamtgewicht des Fahrzeuges

Peso total admisible del vehículo

Ved tilladt samlet vægt for køretøjet