

Mercedes-Benz

A Class	09/2012 >> 04/2018
B Class	02/2012 >> 01/2019
CLA	04/2013 >> 03/2019
CLA Shooting Brake X117	03/2015 >> 08/2019
GLA X156	03/2014 >> 02/2020

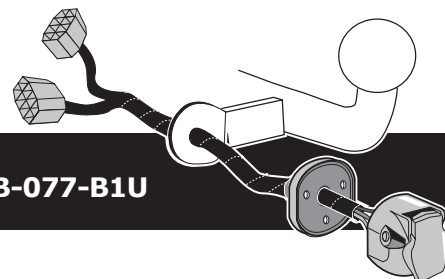

Partnr.: MB-077-B1U

- Fitting instructions electric wiring kit tow bar with 12-N socket up to DIN/ISO Norm 1724.
- We would expressly point out that assembly not carried out properly by a competent installer will result in cancellation of any right to damage compensation, in particular those arising by virtue of the product liability act.
- Contents of these kits and their fitting manuals are subject to alteration without notice, please ensure that these instructions are read and fully understood before commencing installation.
- Do not overload circuits; the maximum loads per connection are detailed in this manual.
- Attention! Before Installation, please read this manual carefully and inform your customer to consult the vehicle owners manual to check for any vehicle modifications required before towing.
- In the event of functional problems, troubleshooting must be limited to about 0.5 hours, contact the technical support:
ts-uk@ecs-electronics.com / 07440 202 052.



Part list

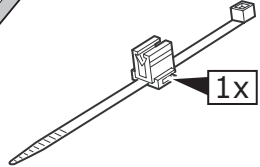
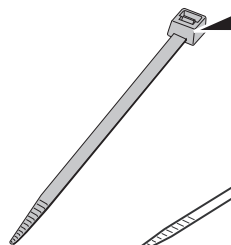
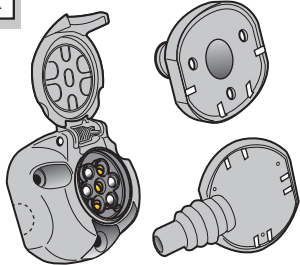
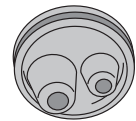
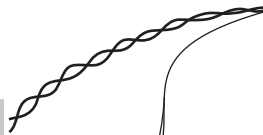
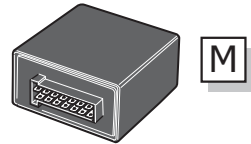
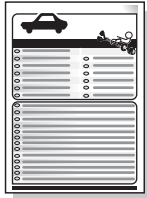
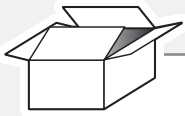

UN-243-YZ

Optional reverse lamp pre-wire extension included



Pag. 10



3x

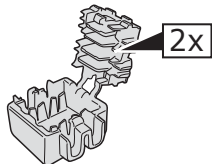

2x

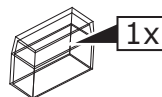

1x

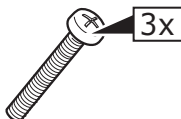

3x

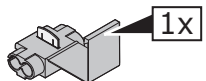

1x

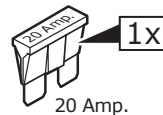

1x

20 Amp.

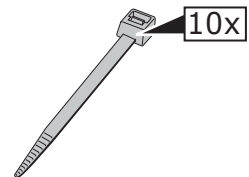

10x

ROUTING

A Class

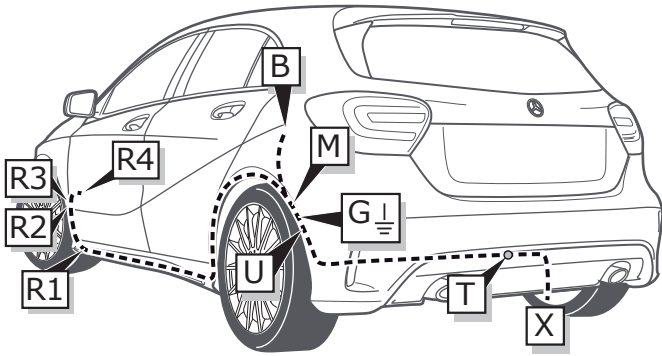

B Class

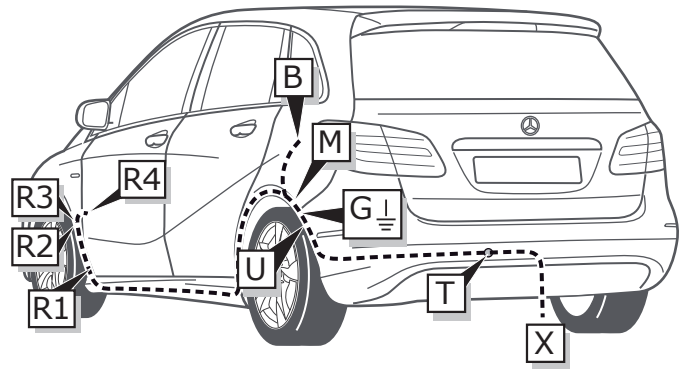

CLA Class

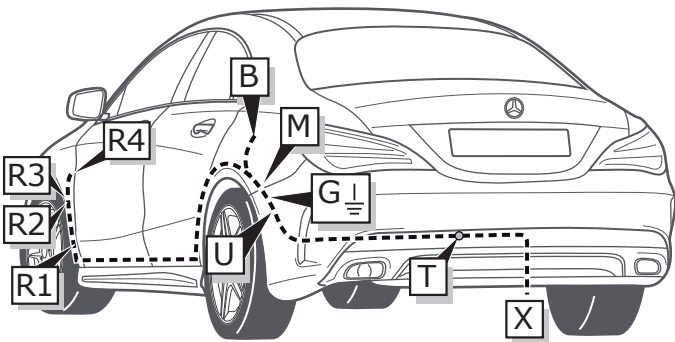

GLA Class

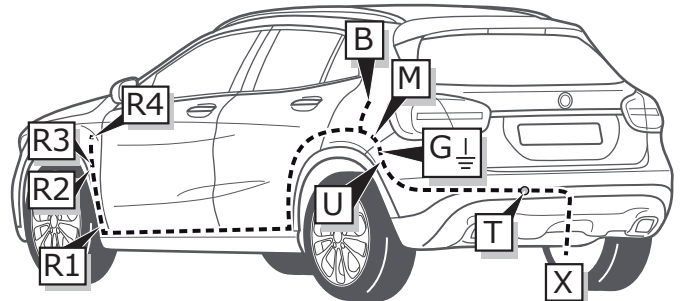

CLA Class Shooting Brake

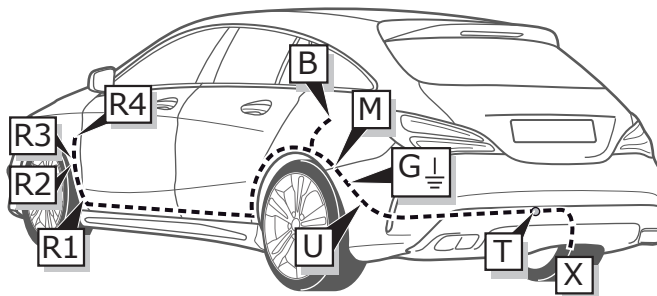

1

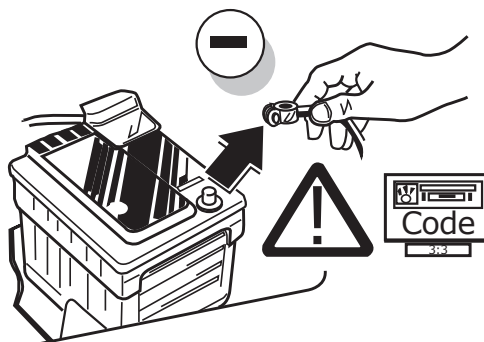

2

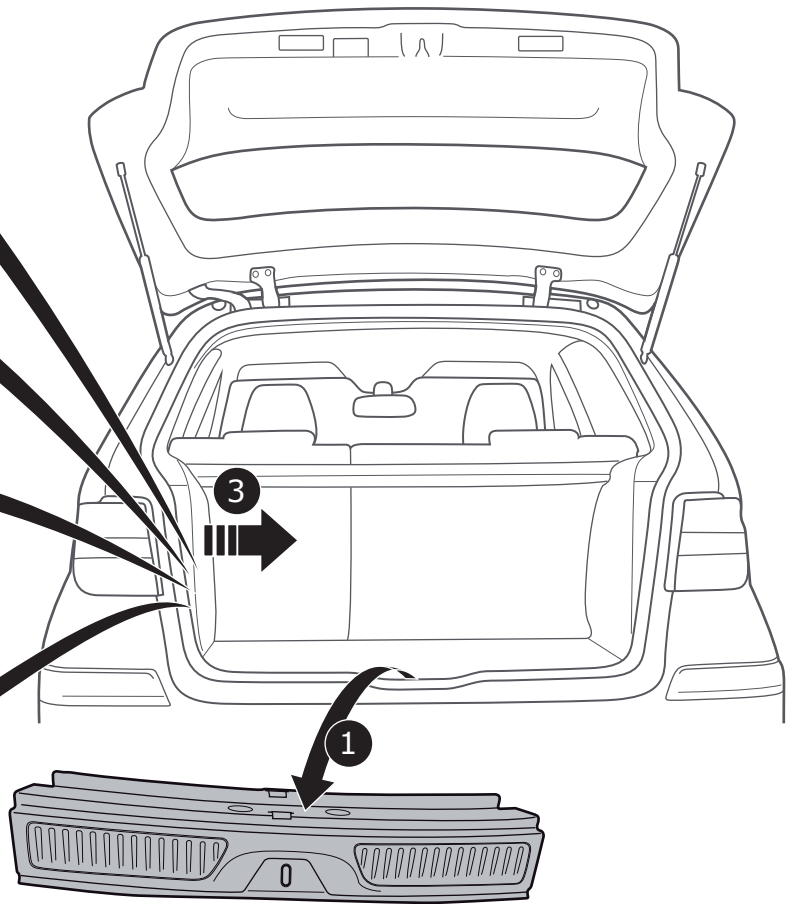
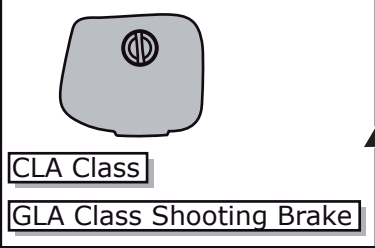
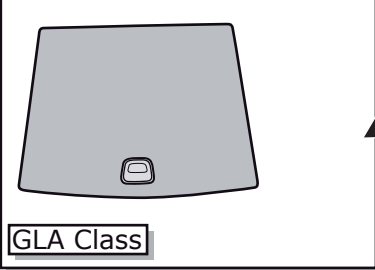
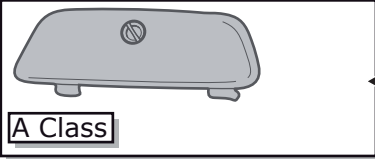
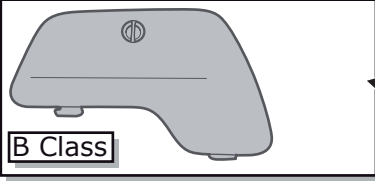

3

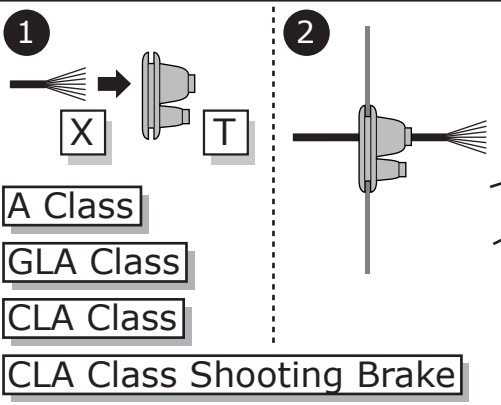
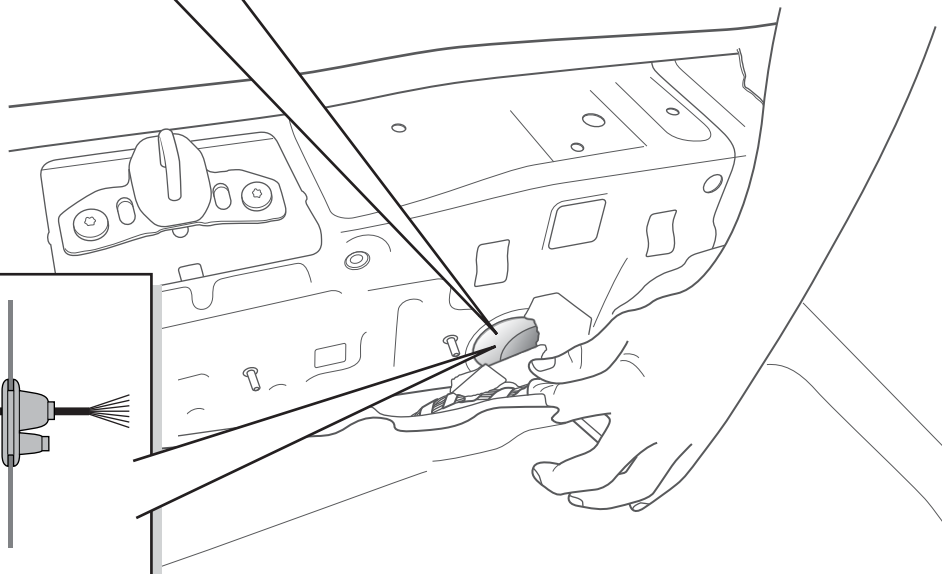
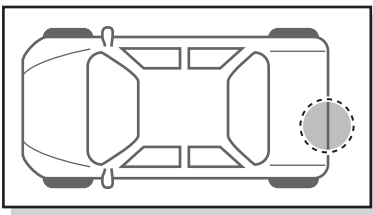
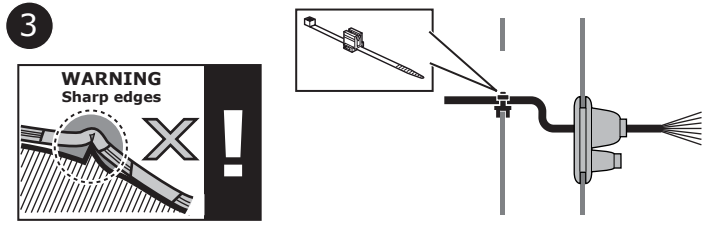
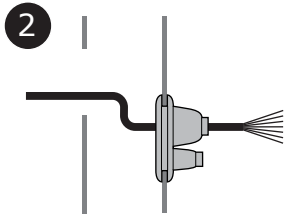
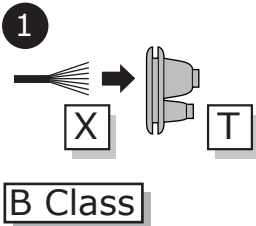

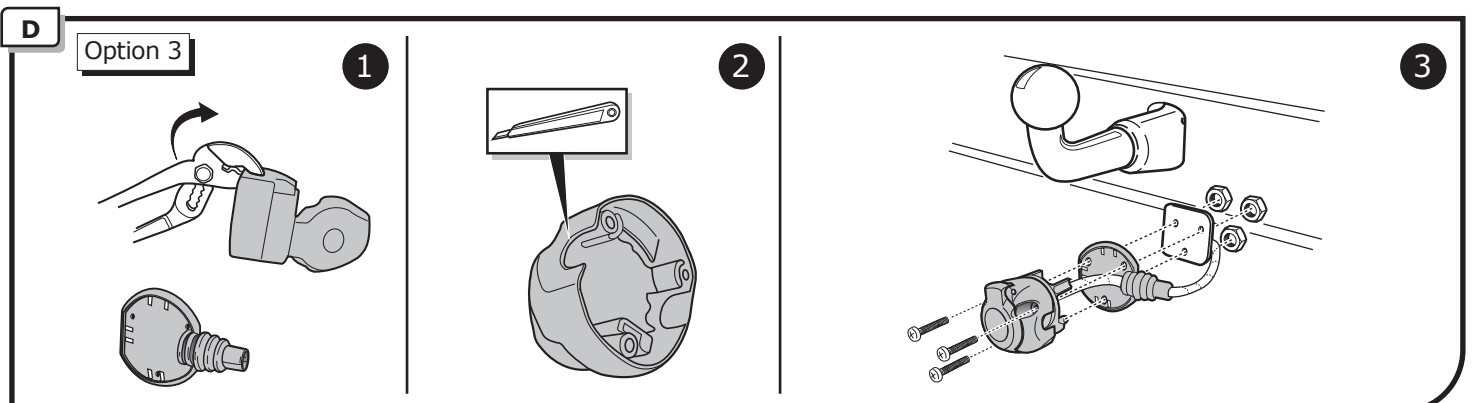
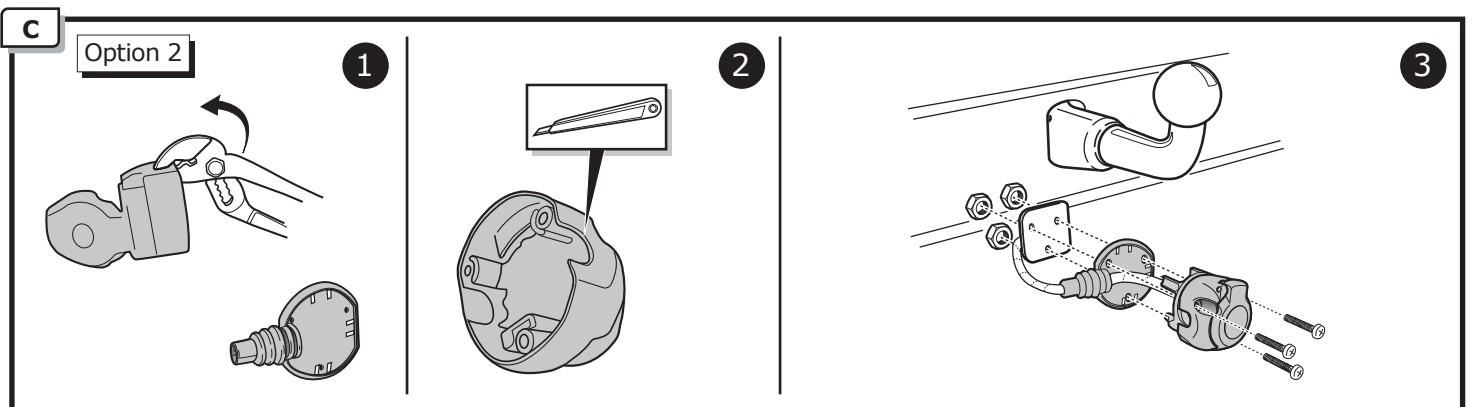
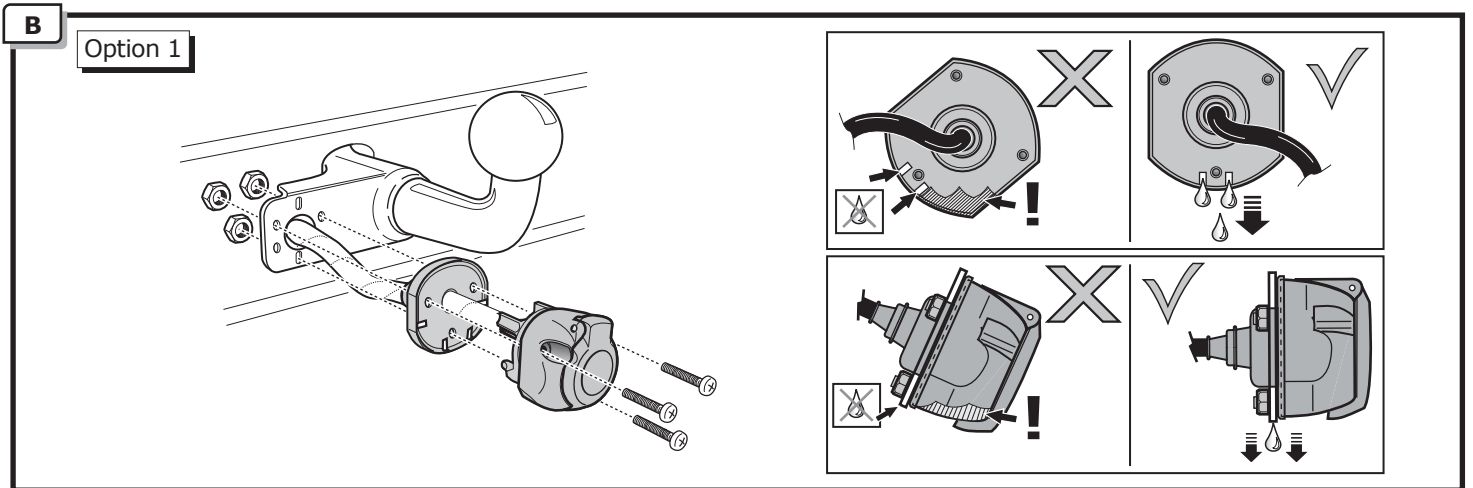
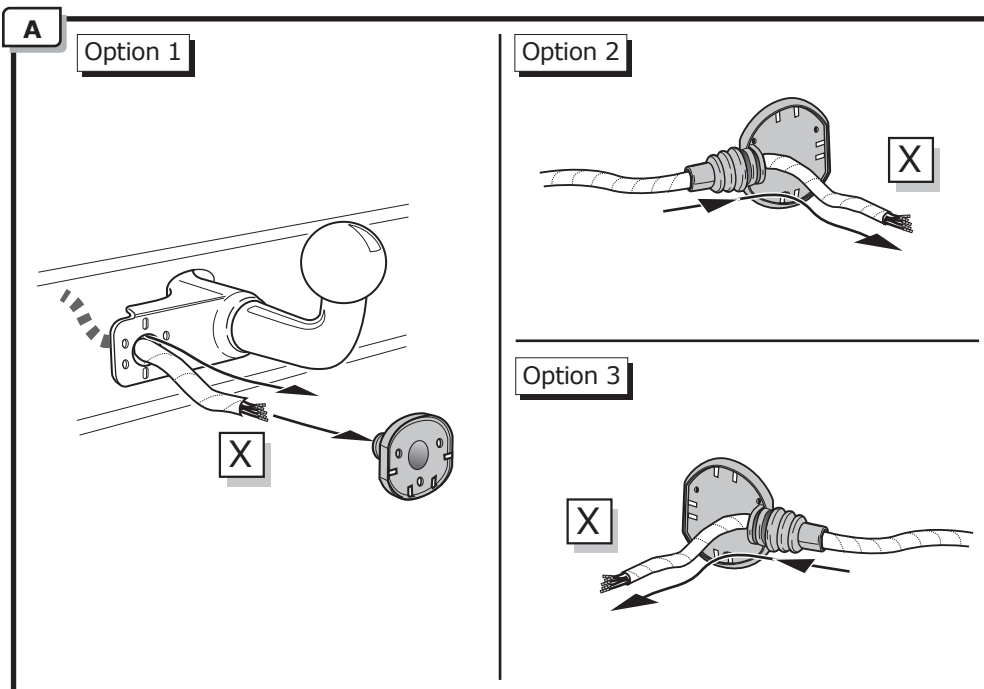

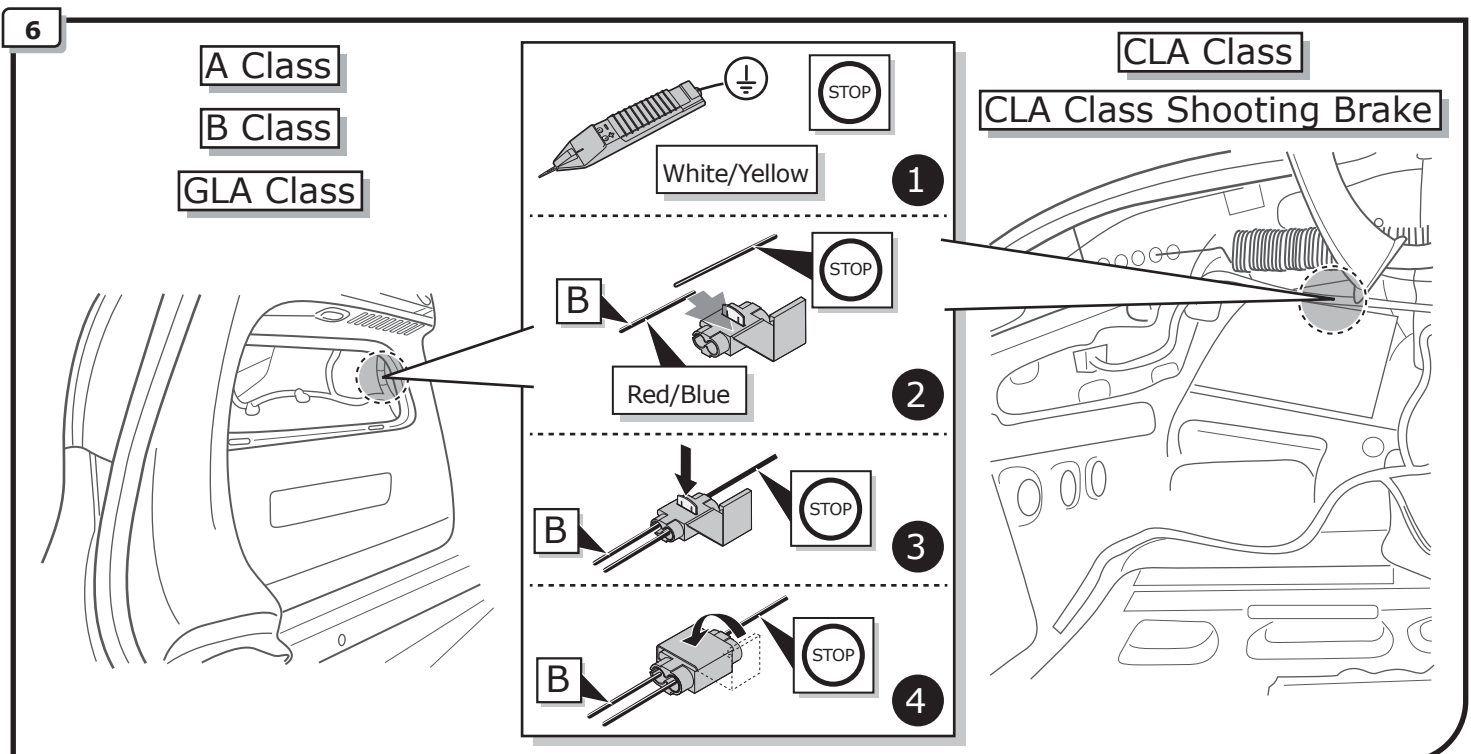
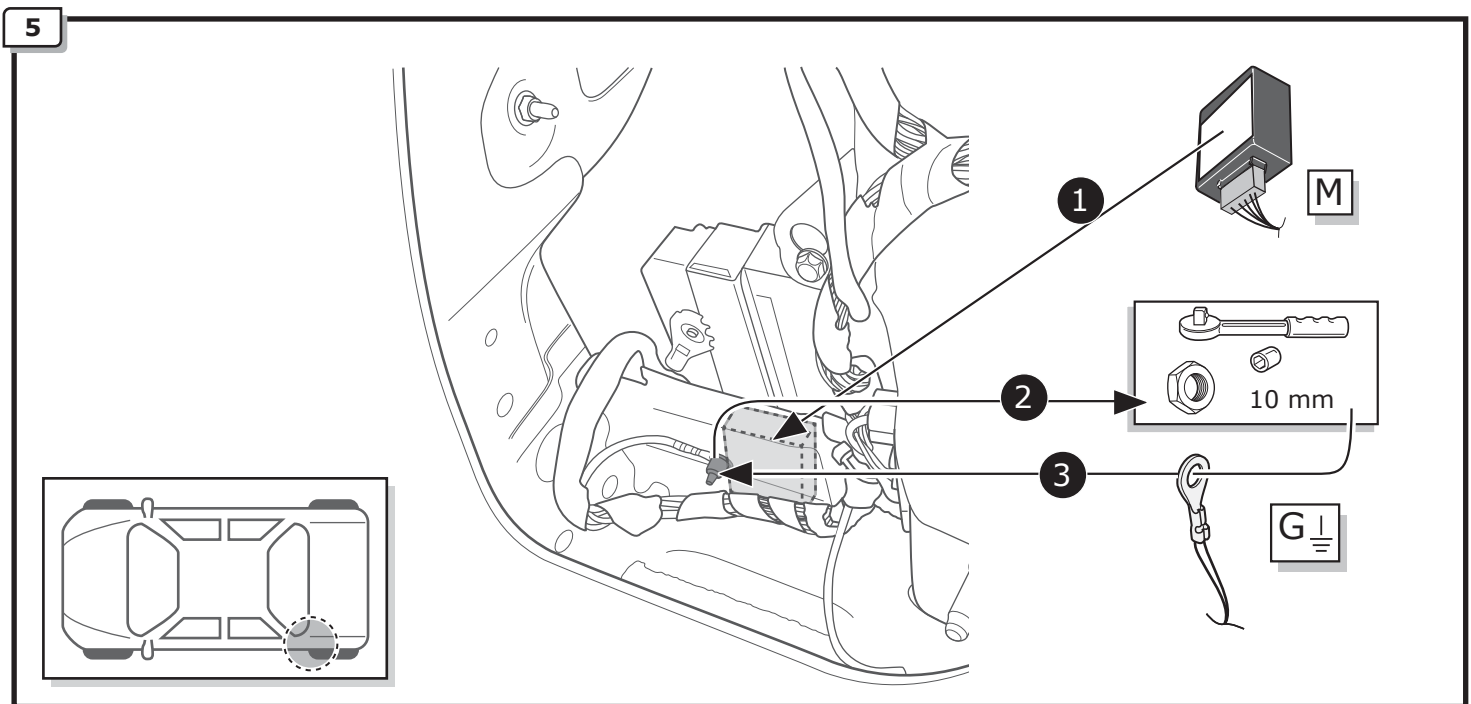
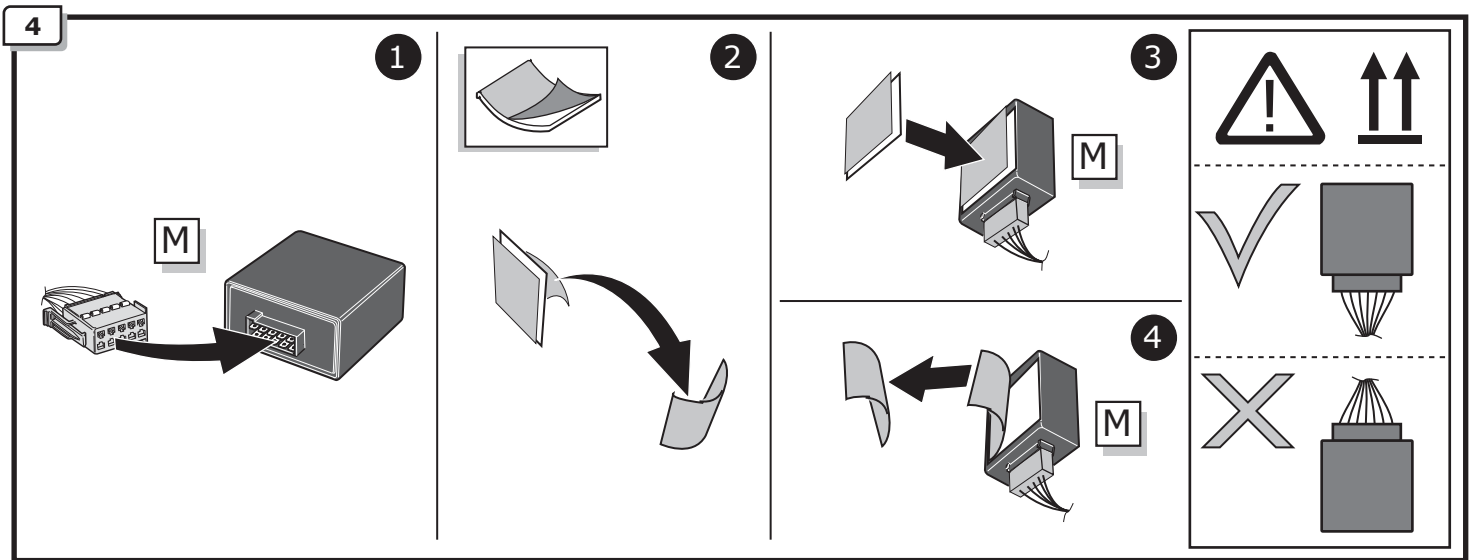

7

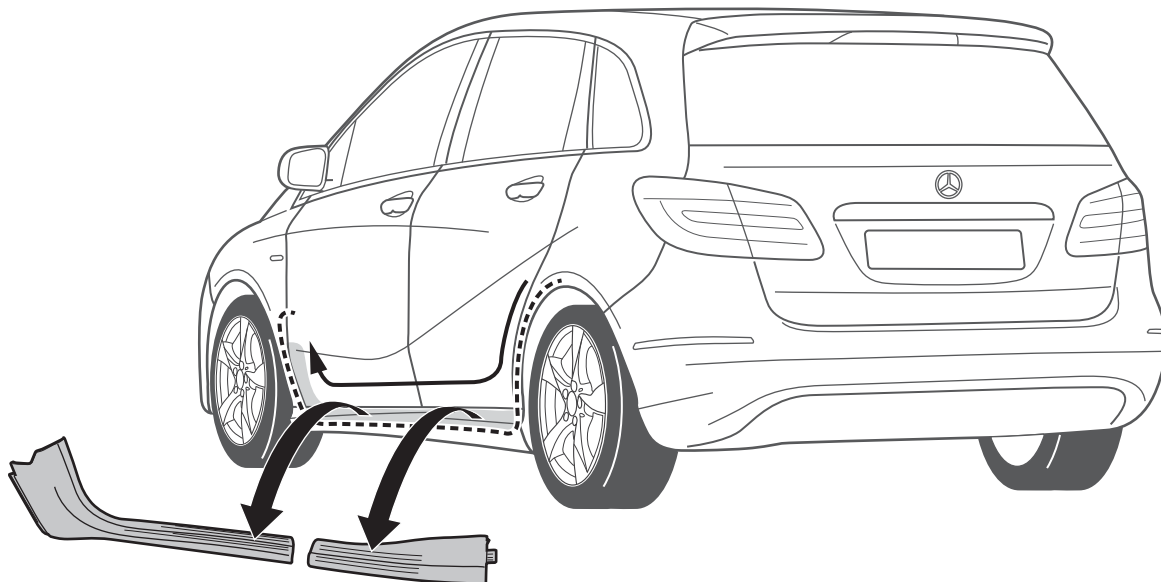

8

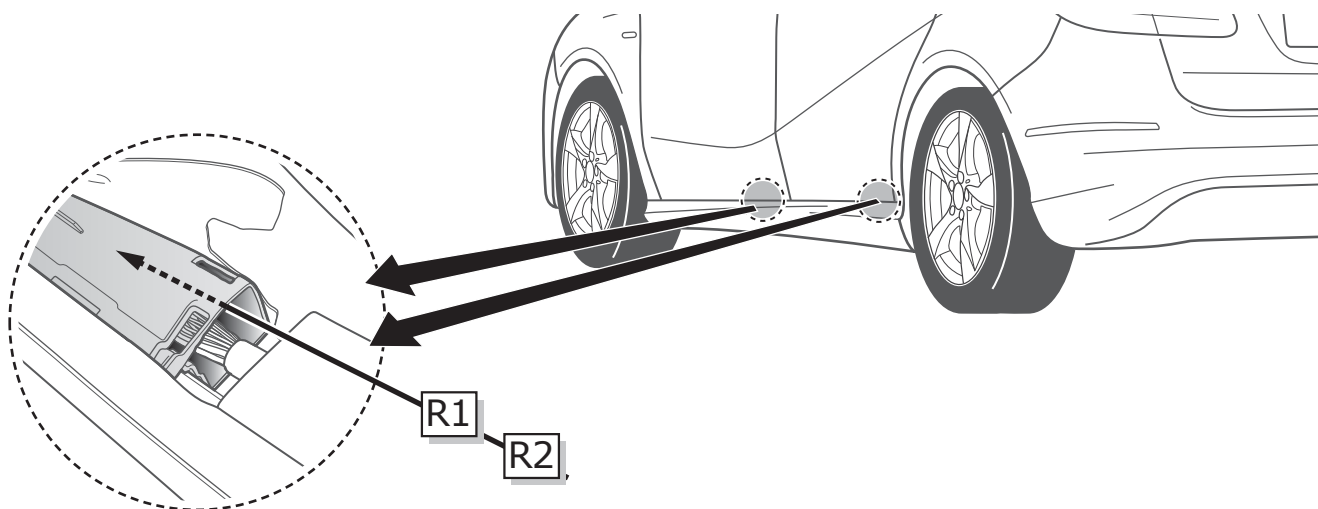

9

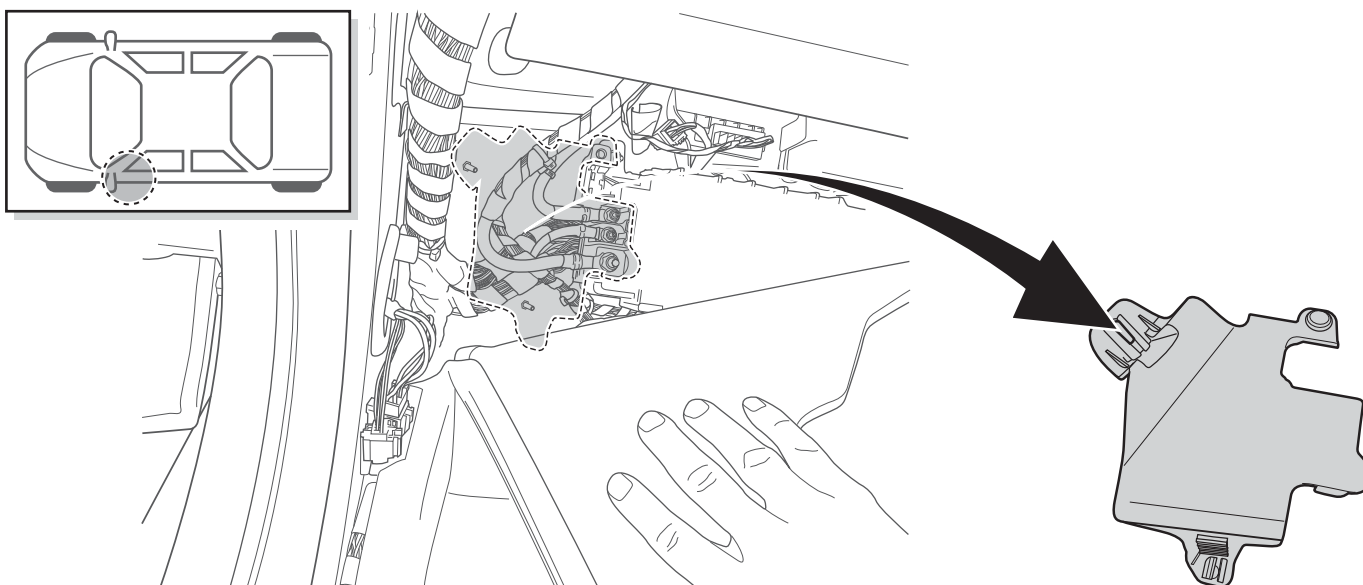

10

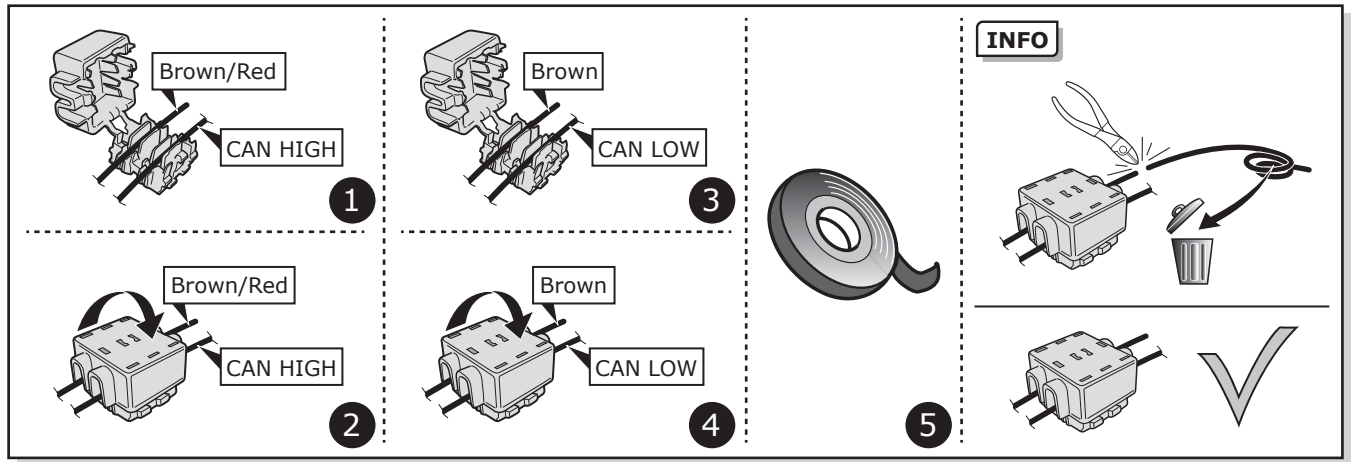
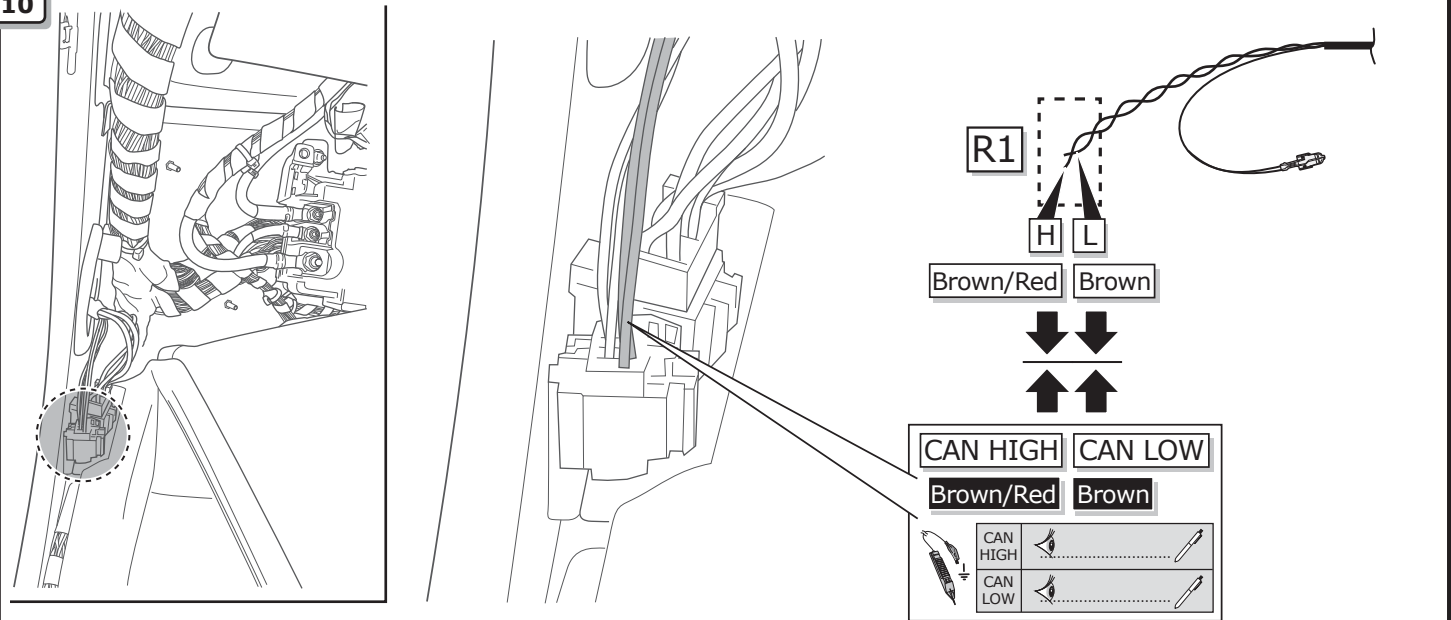

11

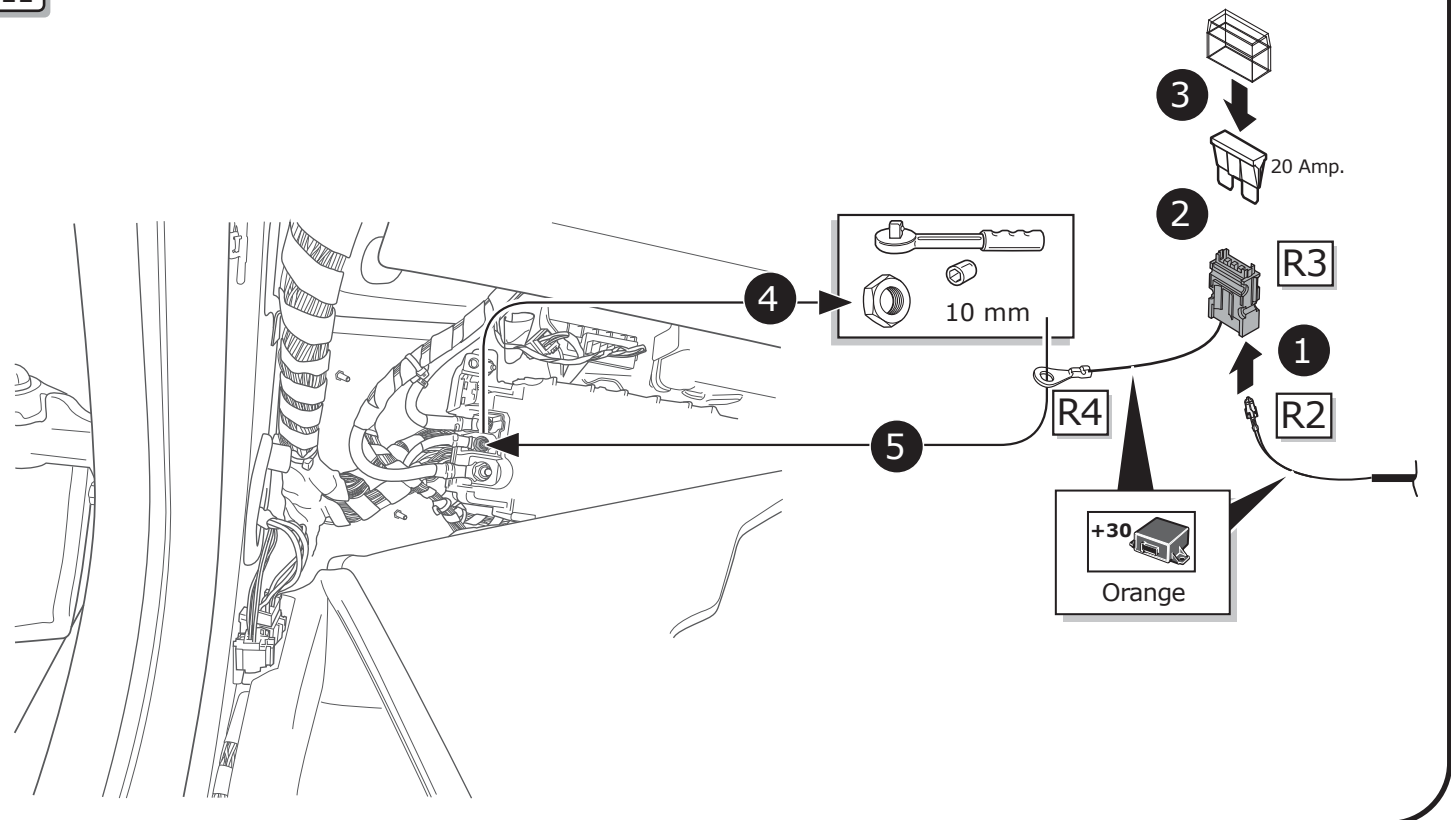

12

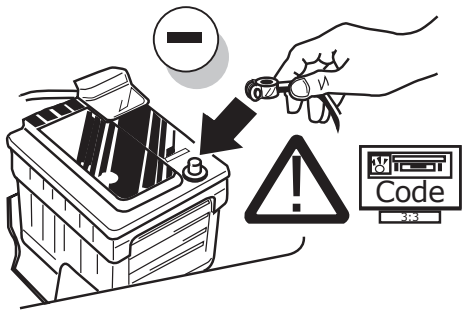

13

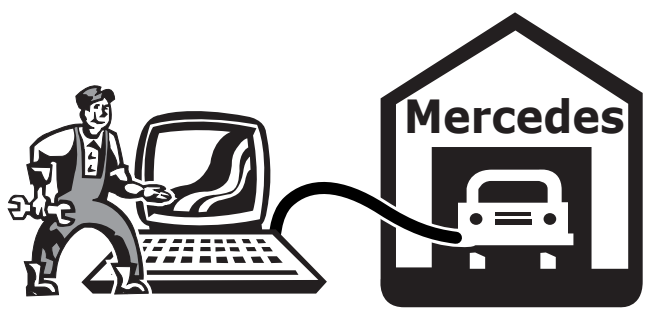

14

TEST ALL THE CIRCUITS WITH A TEST DEVICE WITH THE CORRECT POWER LOAD FOR EACH FUNCTION. A TEST DEVICE WITH LED'S CANNOT BE USED FOR THIS PURPOSE.

INFO

REINSTALL TRIM.

15

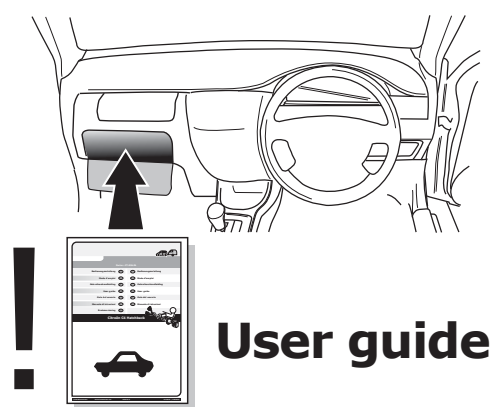

INFO

SOCKET CONNECTION

DIN/ISO 1724							
	1/L	2	3/31	4/R	5/58-R	6/54	7/58-L
Pmax	21W	21W		21W	42W	3x21W	42W
Colour	Yellow	Blue	White	Green	Brown	Red	Black

UN-243-YZ Reverse lamp pre-wire extension

⚠ MAX = 21W

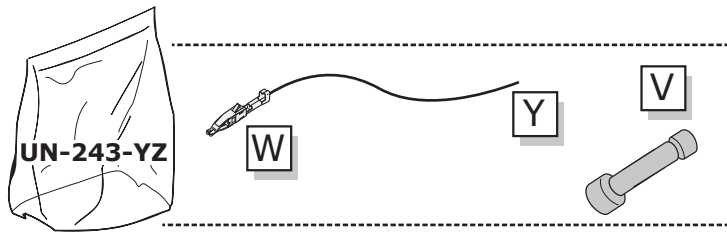

A

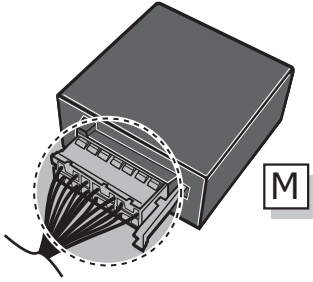

1

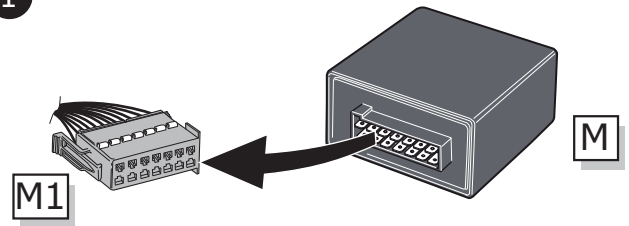

2

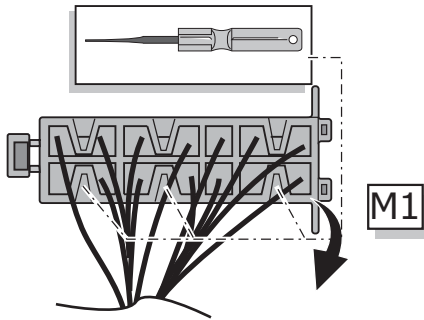

3

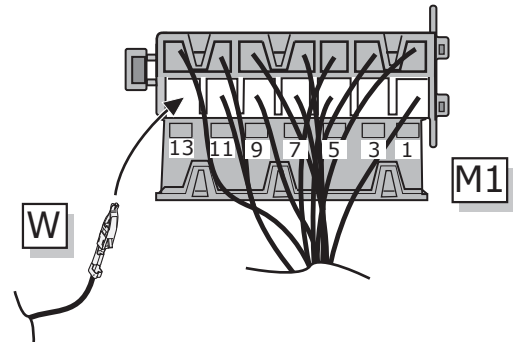

4

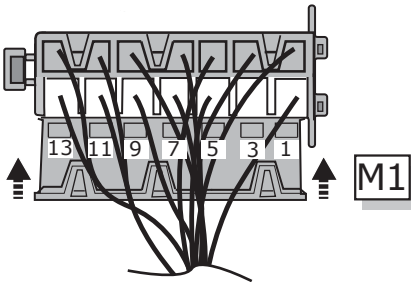

5

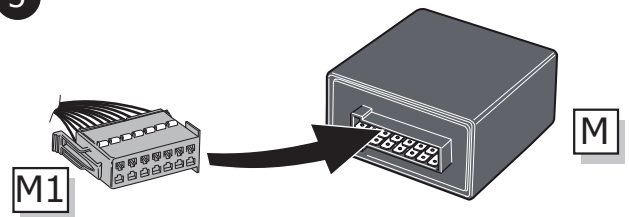

B

⚠ MAX = 21W

