

**Mitsubishi Outlander 2013- & 2016-
Mitsubishi Outlander PHEV 09/2013- & 2016-**

Partnr.: MT-115-DHU

- Fitting instructions electric wiring kit tow bar with 13-P socket up to DIN/ISO Norm 11446.
- We would expressly point out that assembly not carried out properly by a competent installer will result in cancellation of any right to damage compensation, in particular those arising by virtue of the product liability act.
- Contents of these kits and their fitting manuals are subject to alteration without notice, please ensure that these instructions are read and fully understood before commencing installation.
- Do not overload circuits; the maximum loads per connection are detailed in this manual.
- Attention! Before Installation, please read this manual carefully and inform your customer to consult the vehicle owners manual to check for any vehicle modifications required before towing.
- In the event of functional problems, troubleshooting must be limited to about 0.5 hours, contact the technical support:
ukts@ecs-electronics.com / 07440 202 052.



Part list

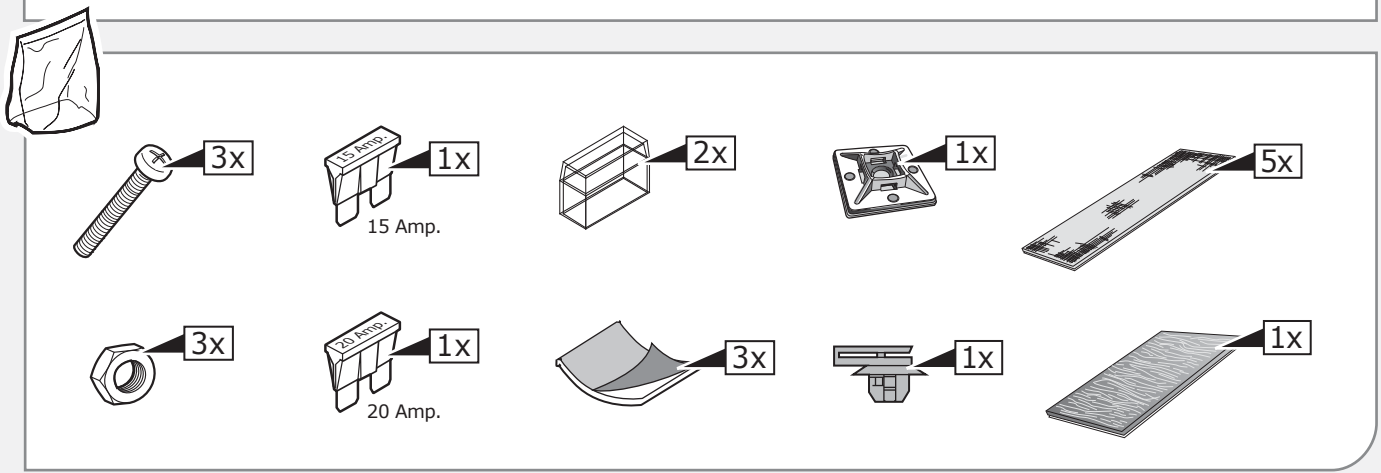
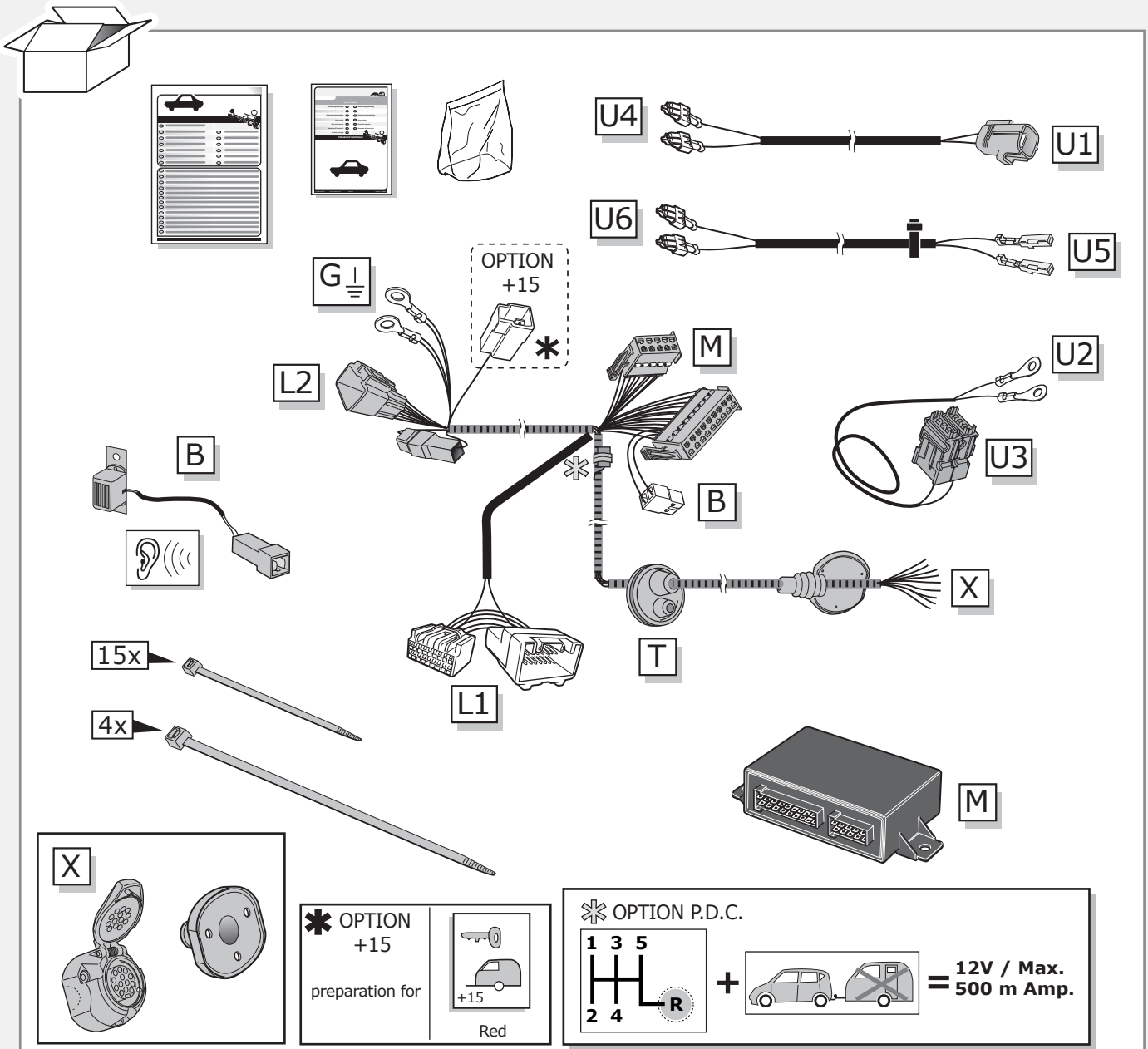

**Mitsubishi Outlander
2013- & 2016-**

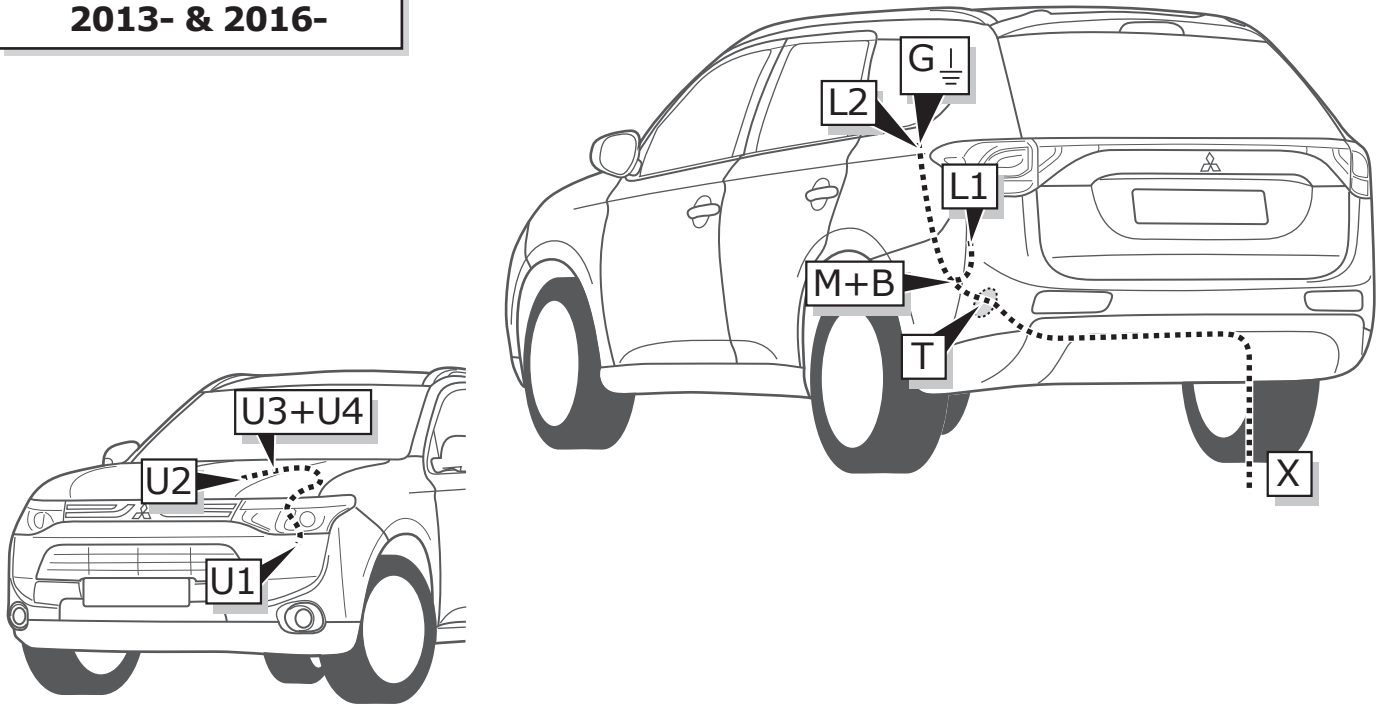

**Mitsubishi Outlander
PHEV 09/2013-
&
PHEV 2016-**

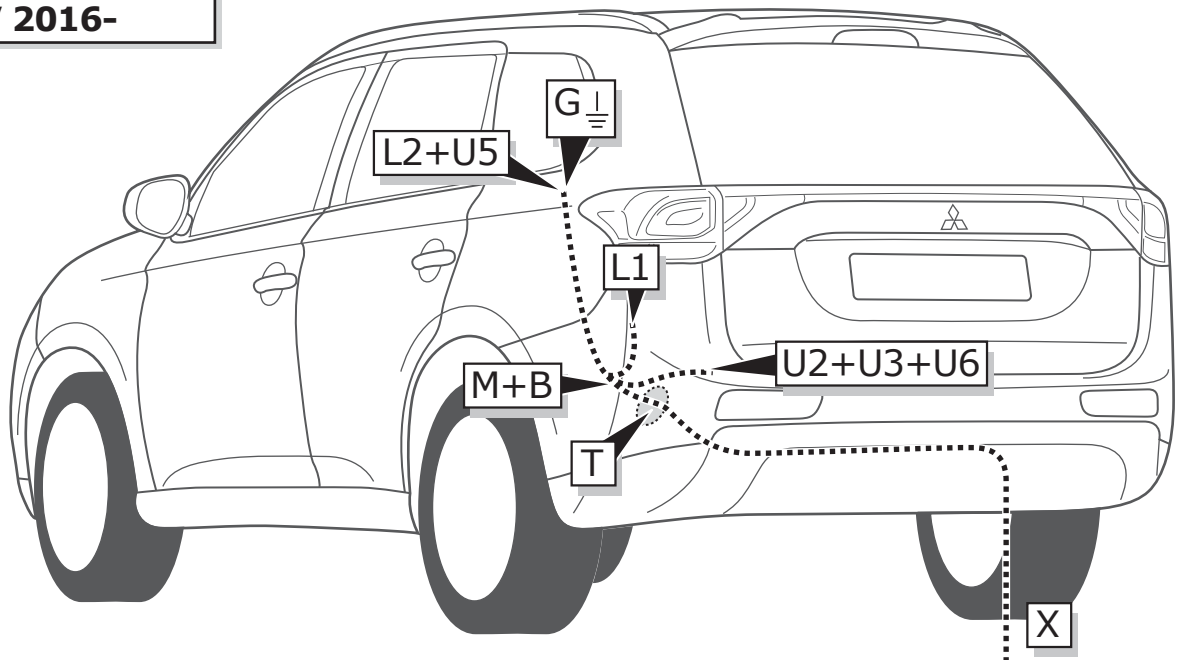

1

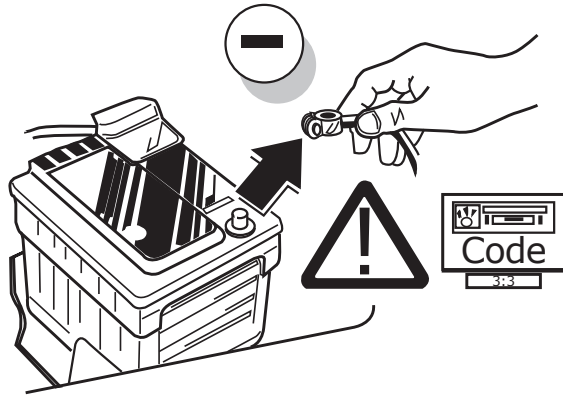

2

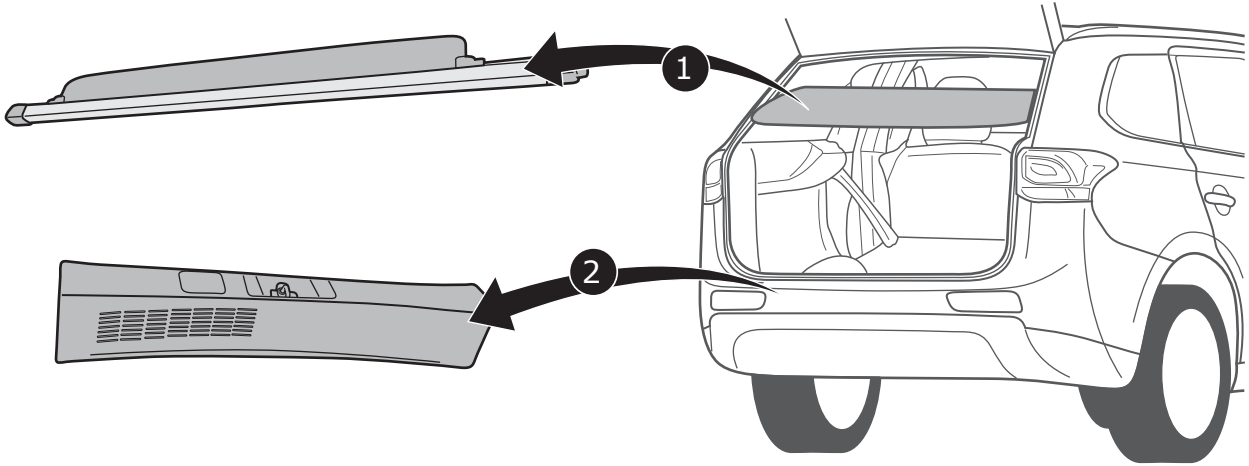

3

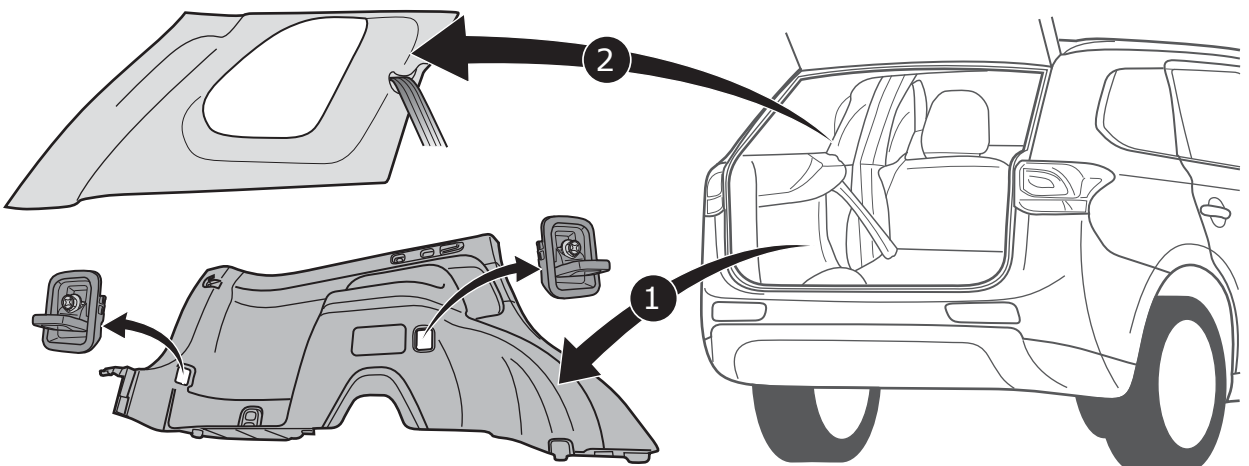

4

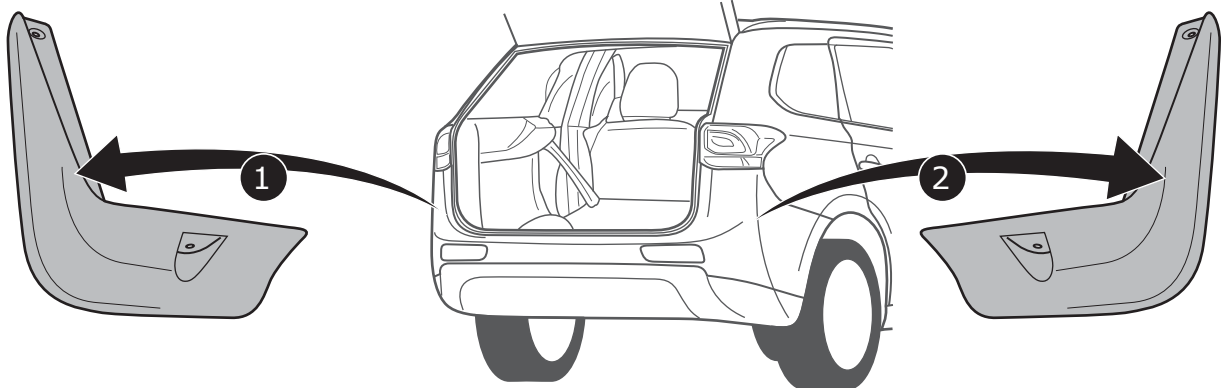

5

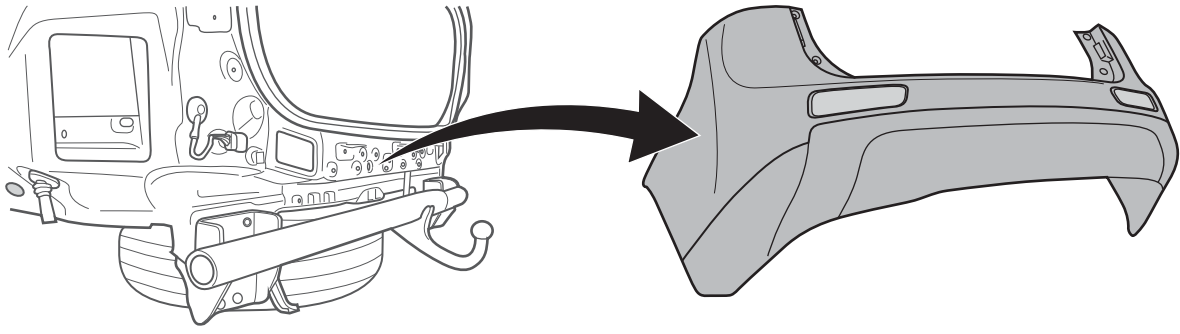

6

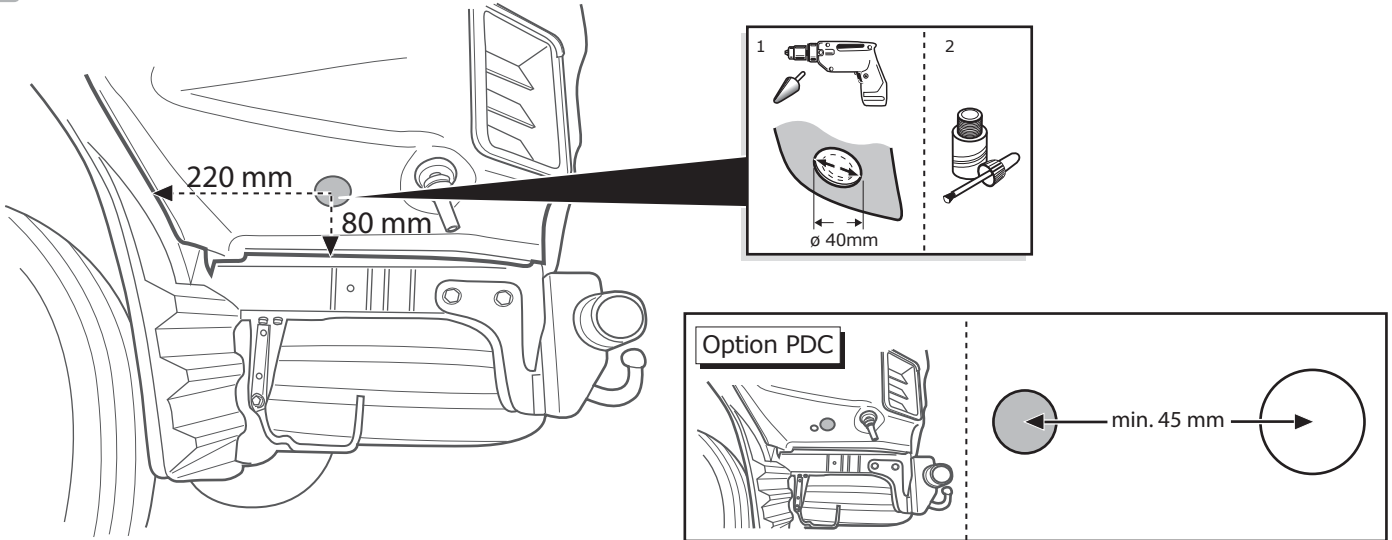

7

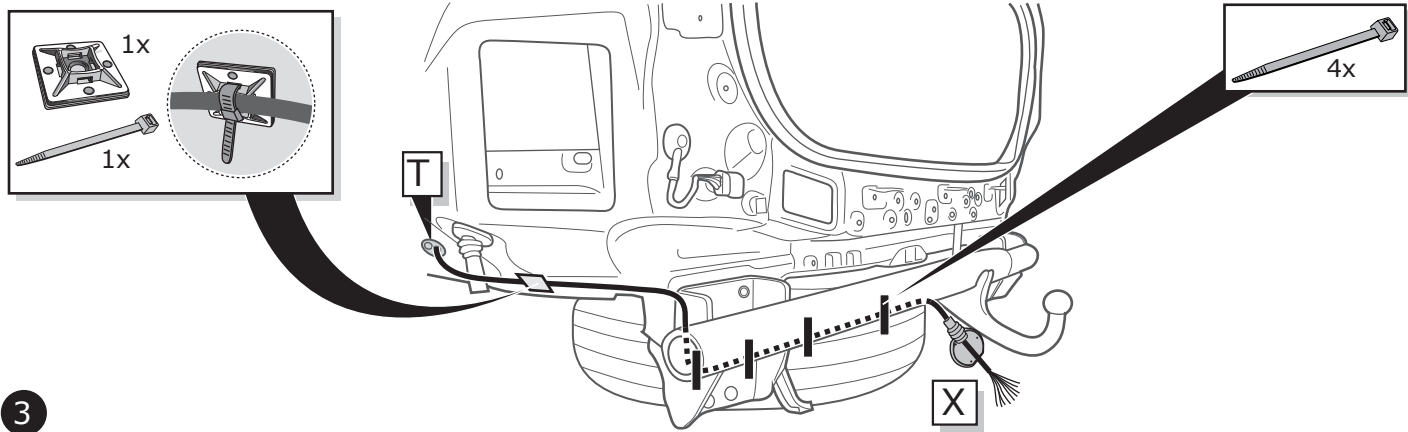
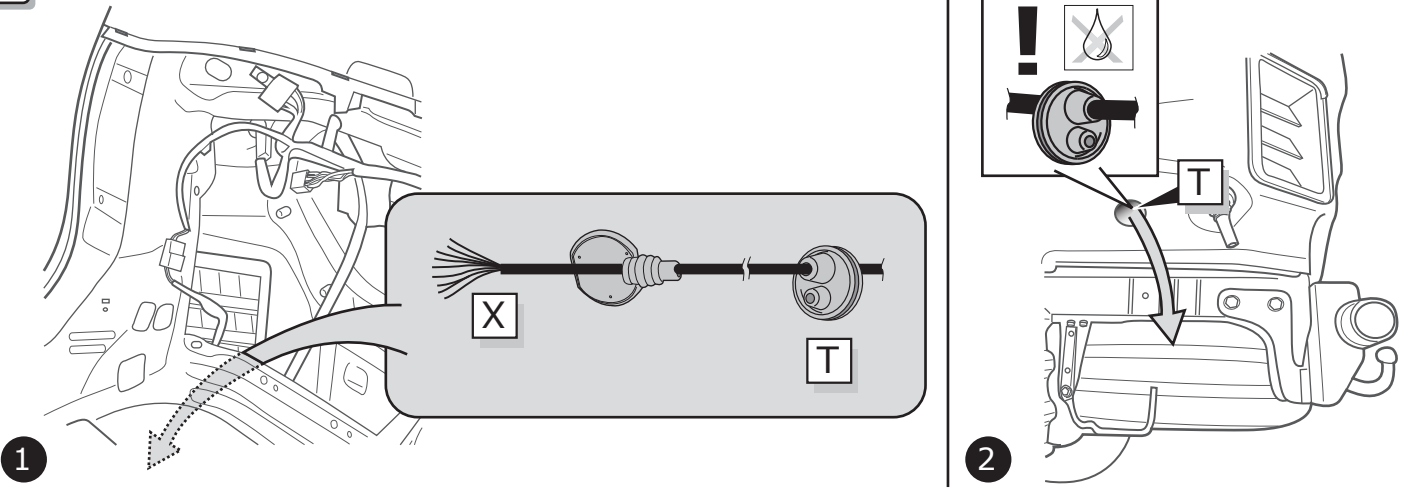

3

SOCKET CONNECTION



8

Option 1

1

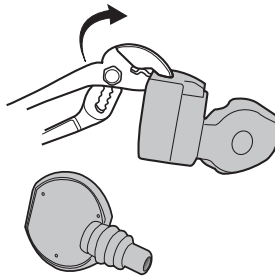

2

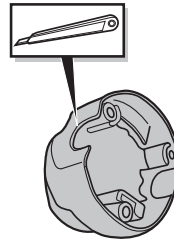

3

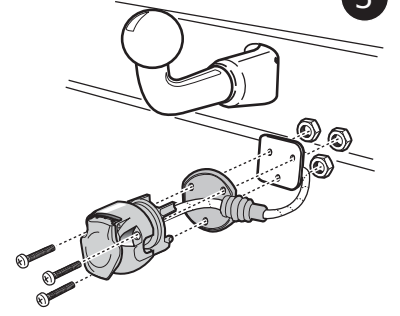

4

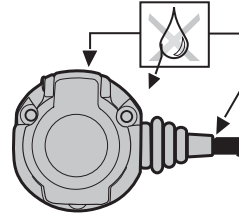

8A

Option 2

1

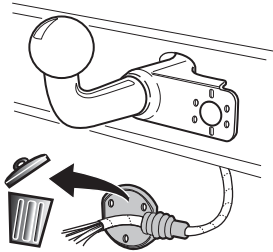

2

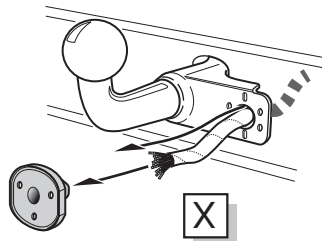

3

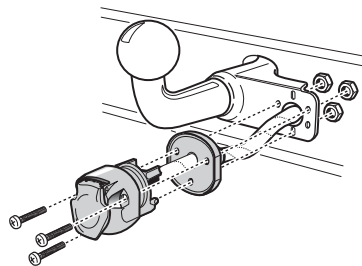

4

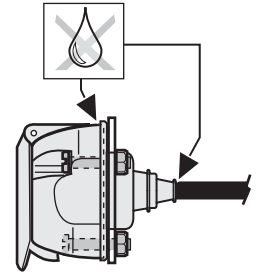

ONLY for PHEV models 2016-

9

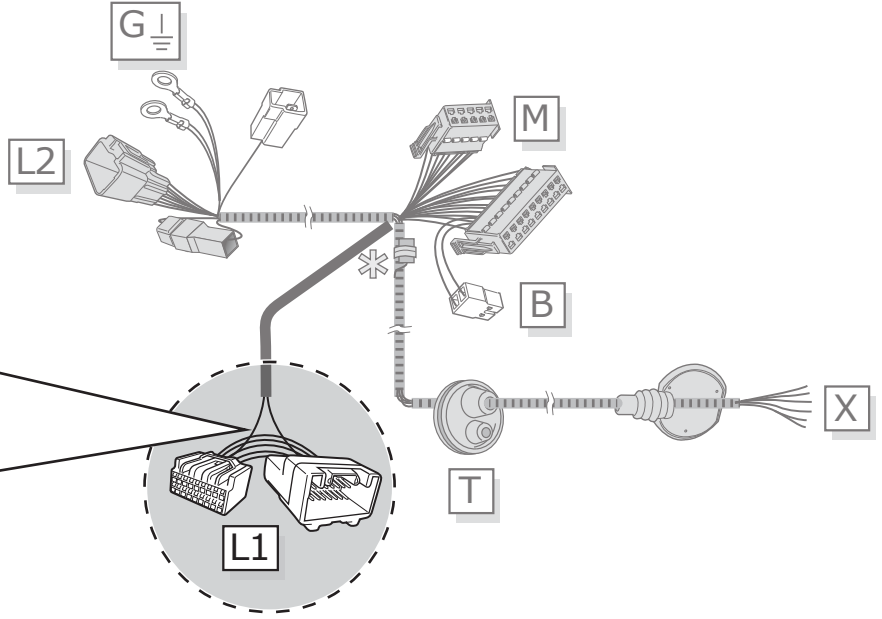
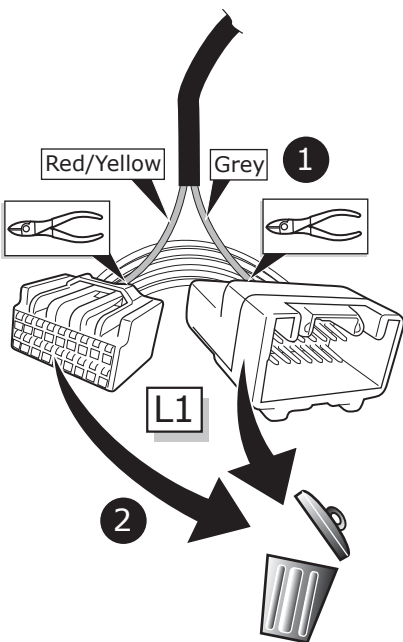

ONLY for PHEV models 2016-

10

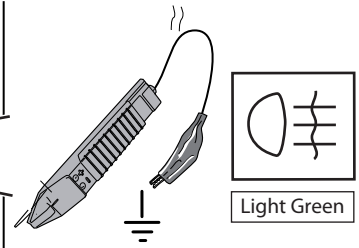
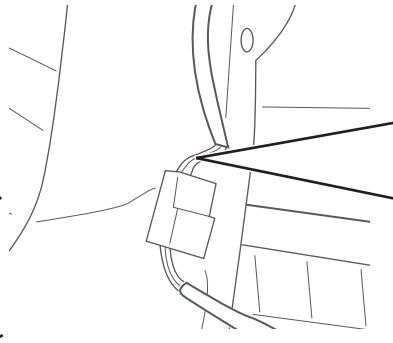
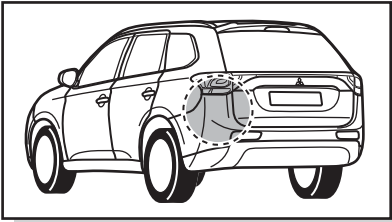

1

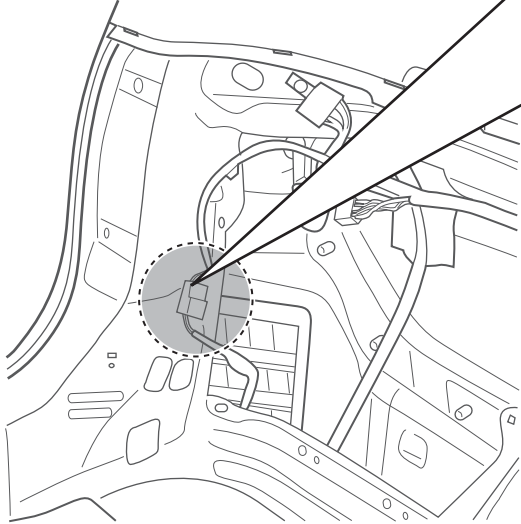

2

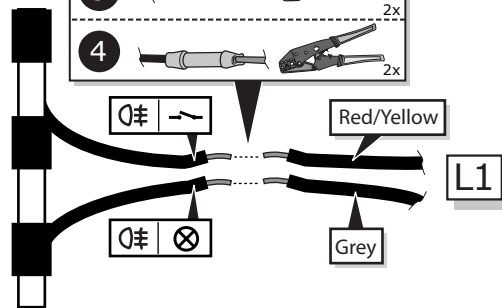
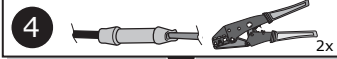
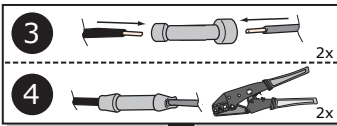
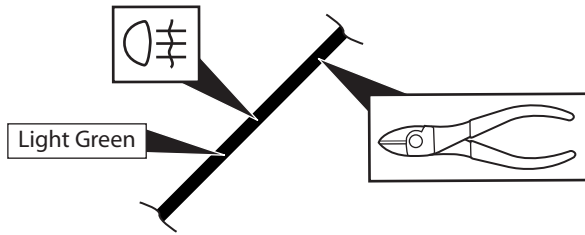

4



12

Other models

11

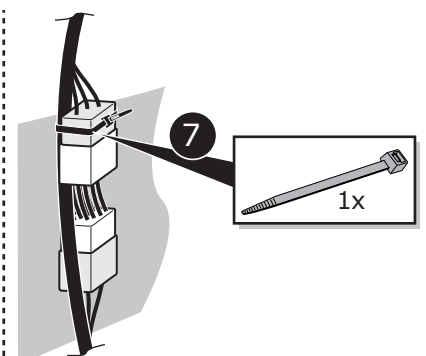
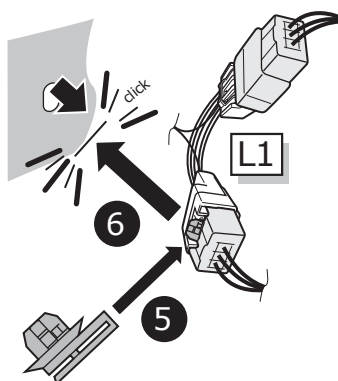
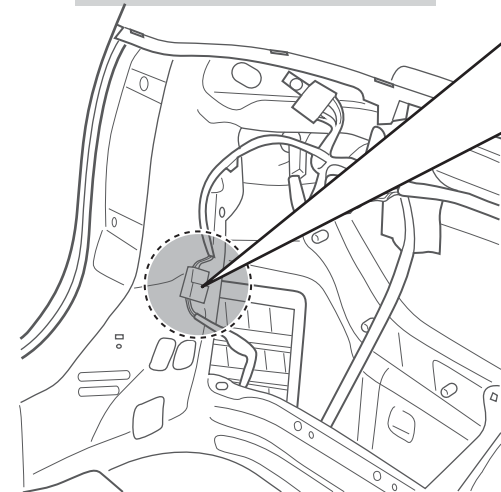
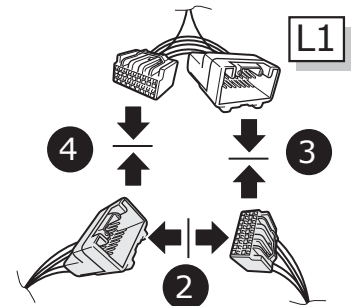
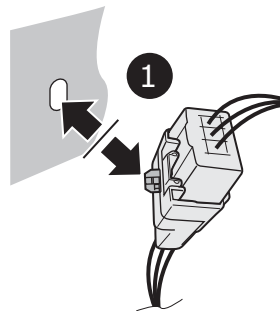
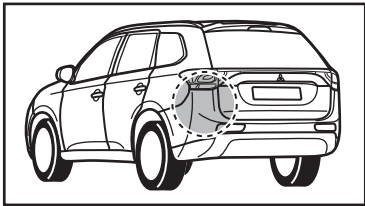

12

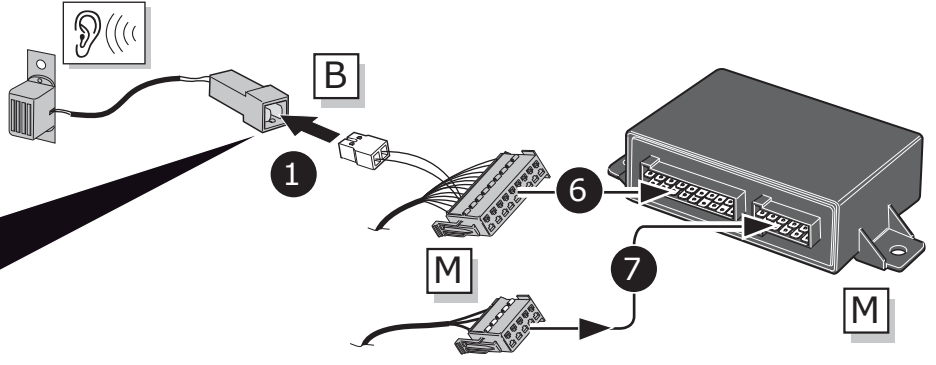
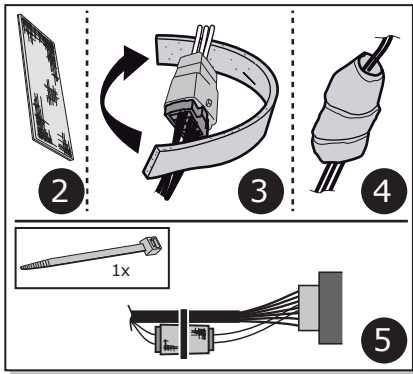

13

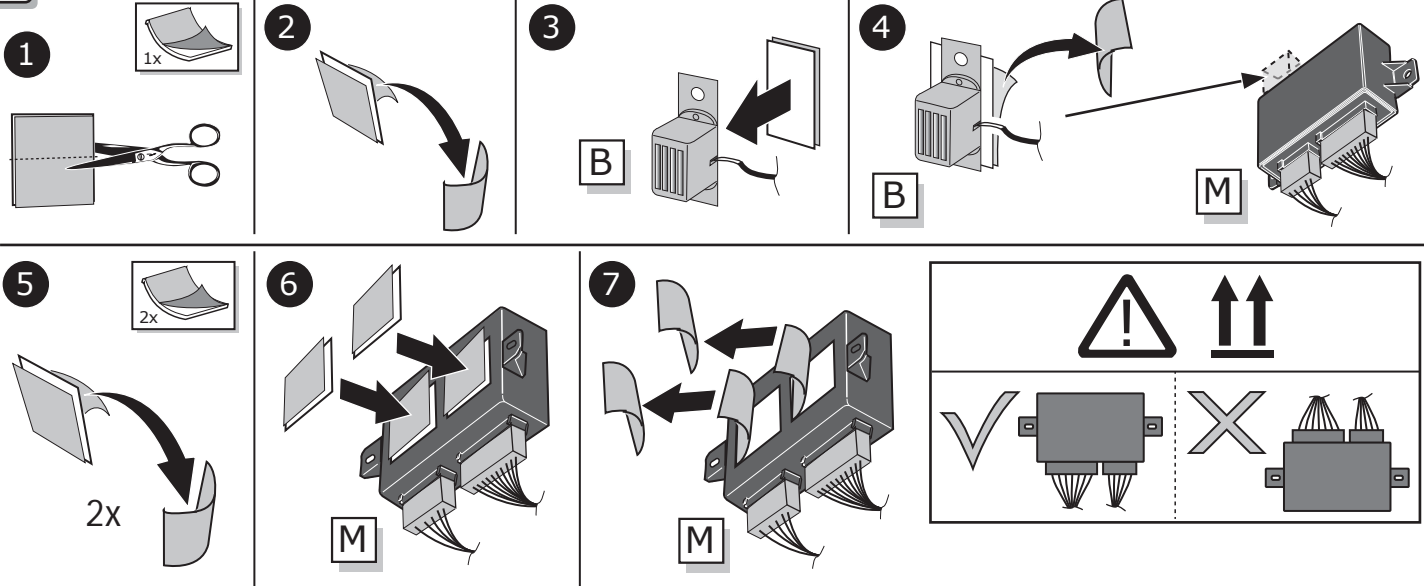

14

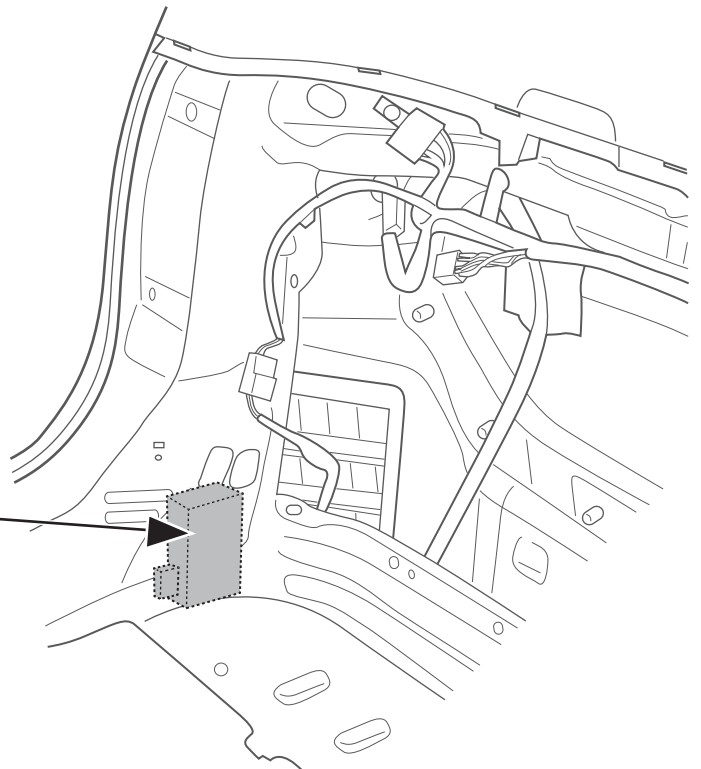
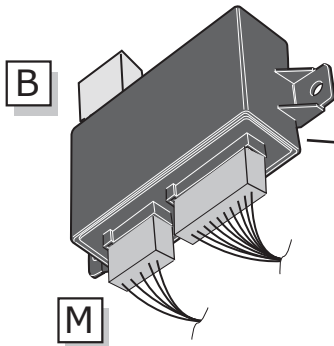
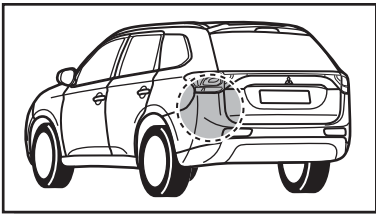

OPTION 1: without electrical tail gate opener

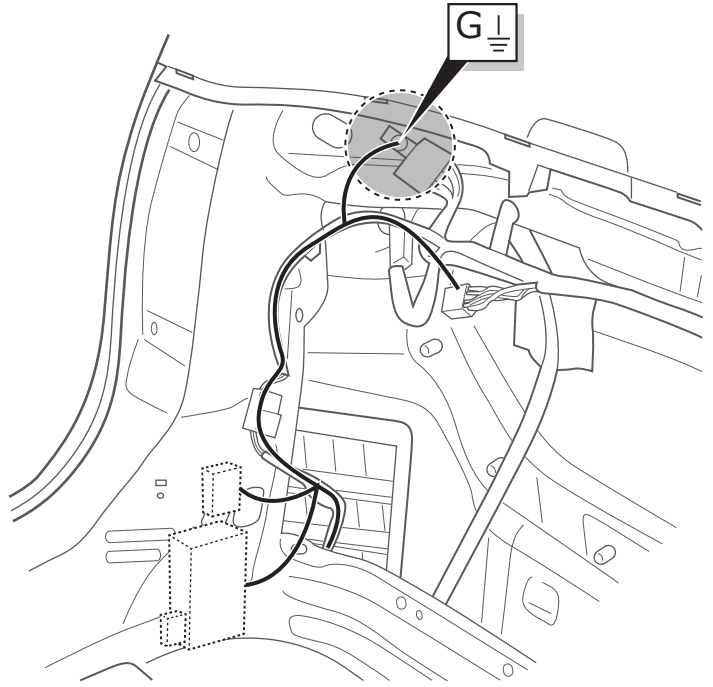
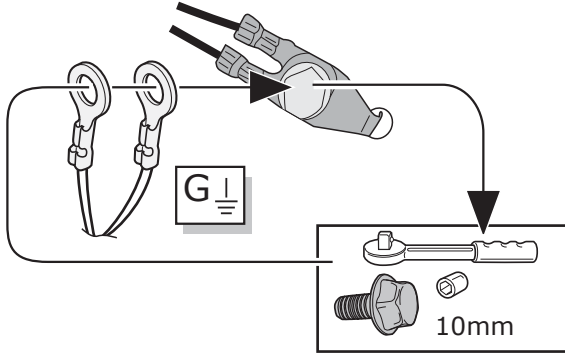
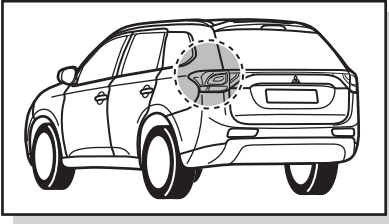

OPTION 2: with electrical tail gate opener

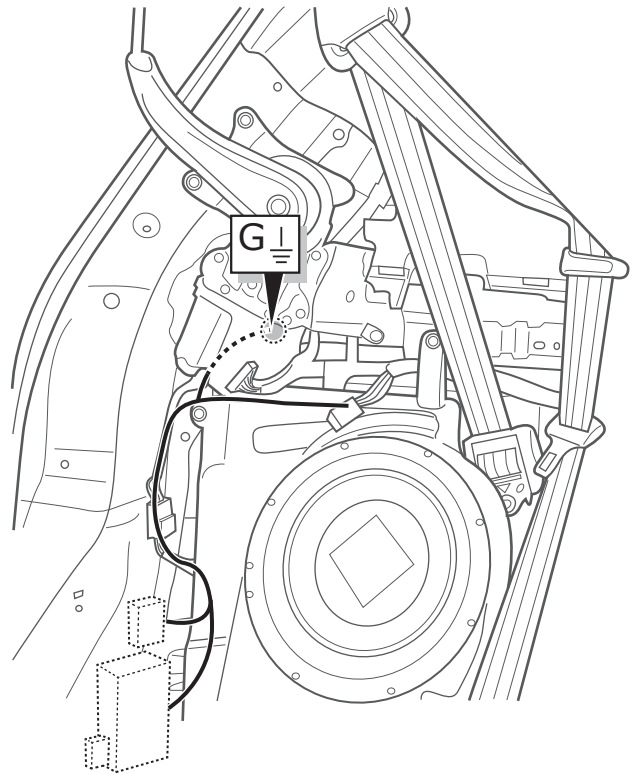
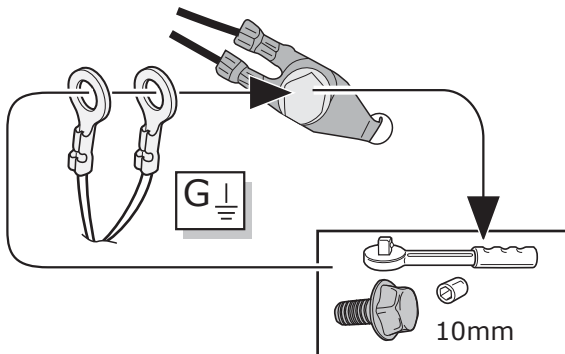
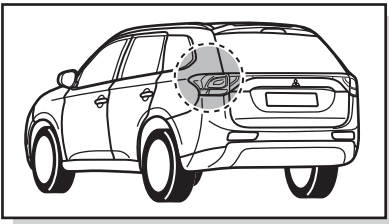

**Option 1:
Mitsubishi Outlander 2013- & 2016-**



**Option 2:
Mitsubishi Outlander
PHEV 09/2013-
&
PHEV 2016-**



17

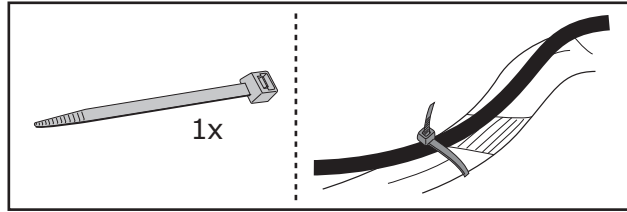
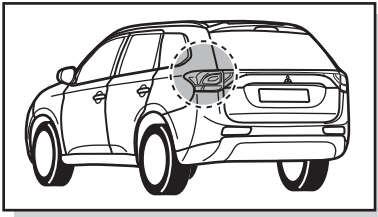

1

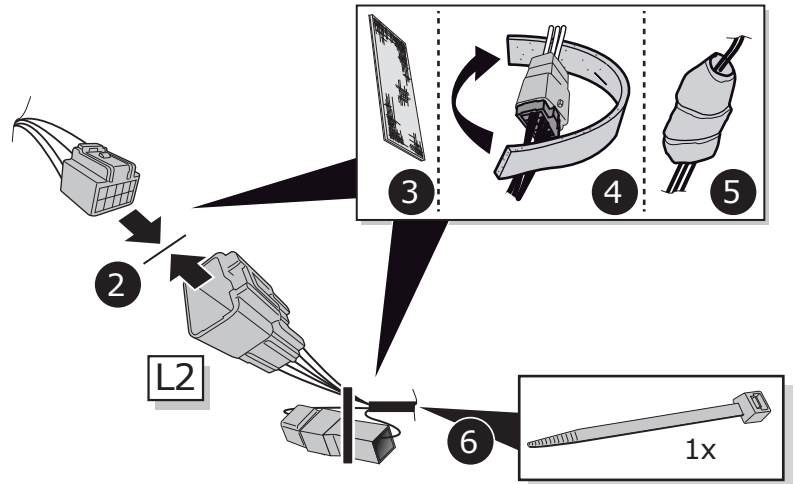
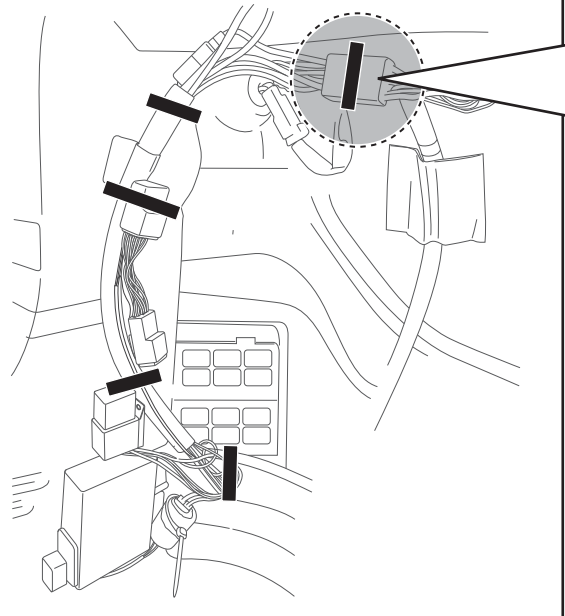

18

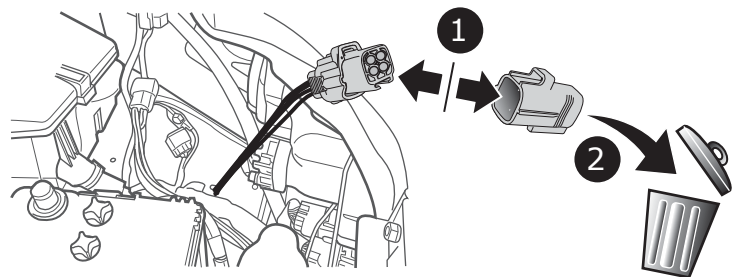
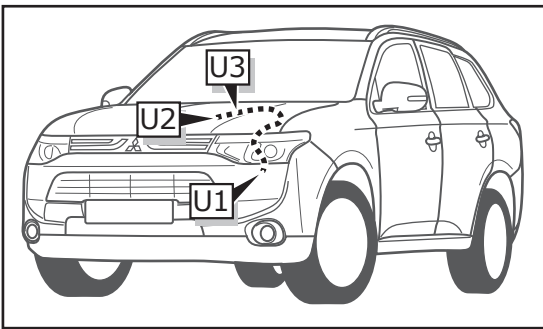

3

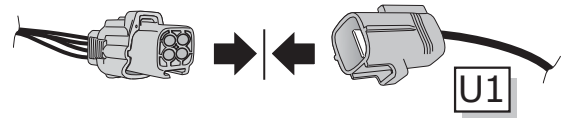

4

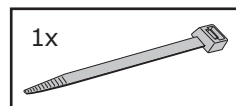

U1

19

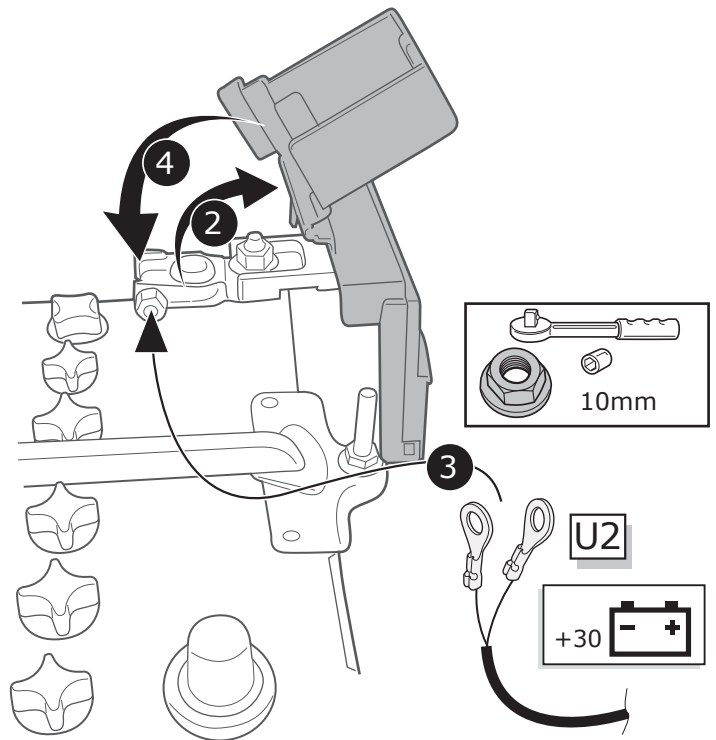
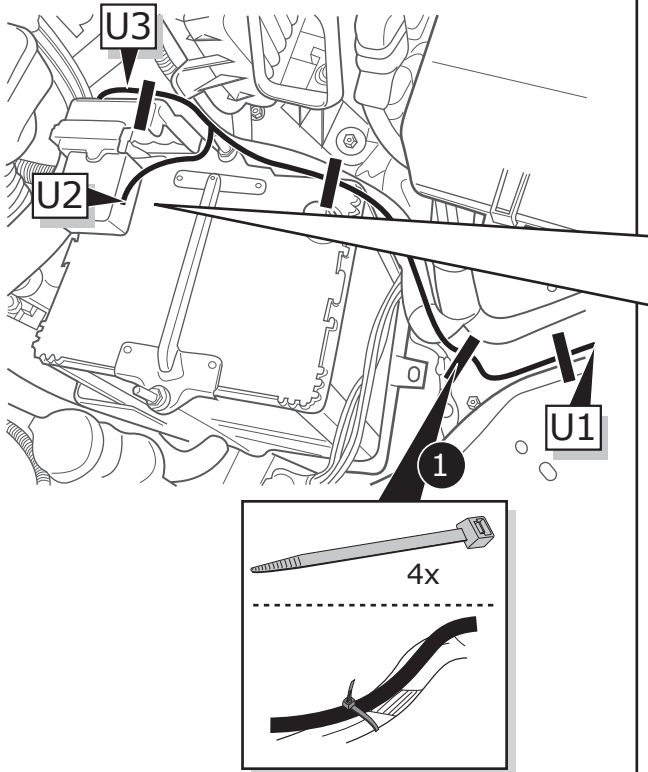

20

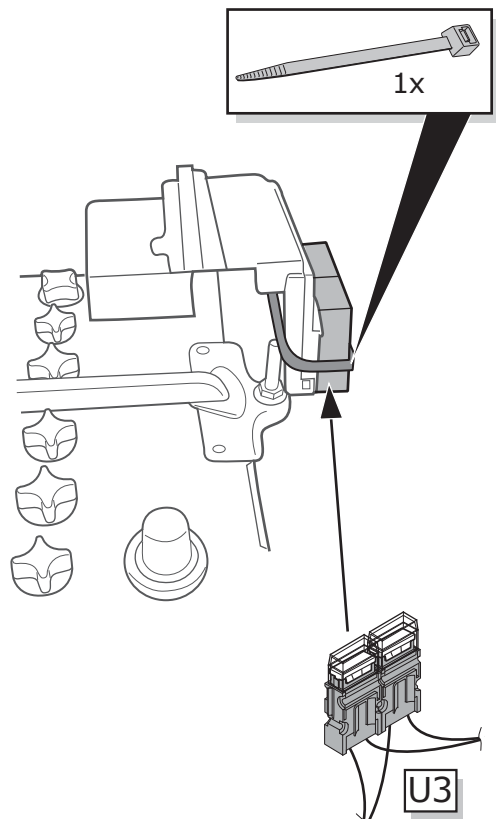
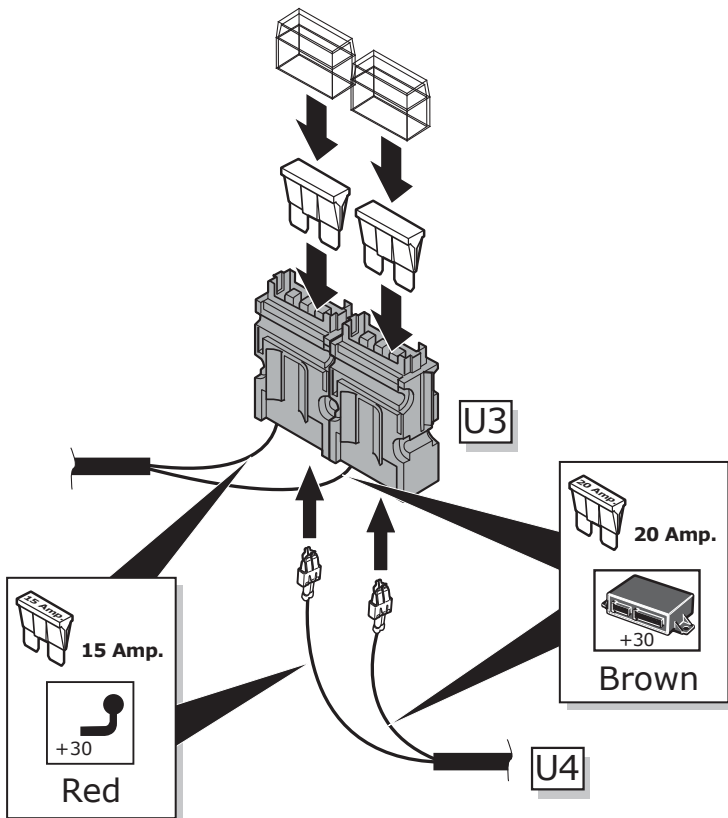

2

21

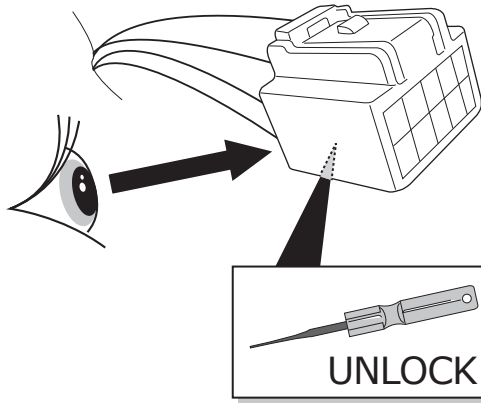
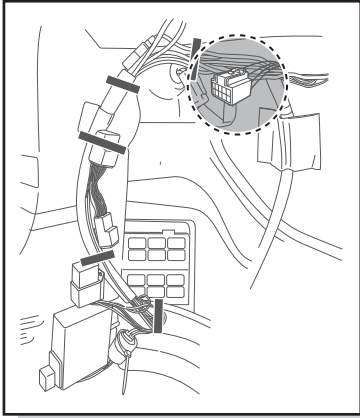

22

Option 1:
positions free

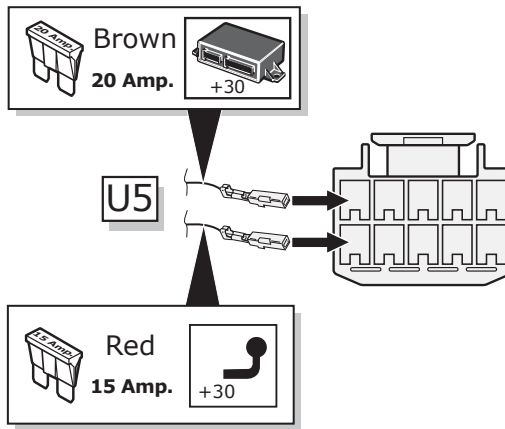
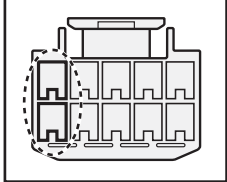

Option 2:
positions taken

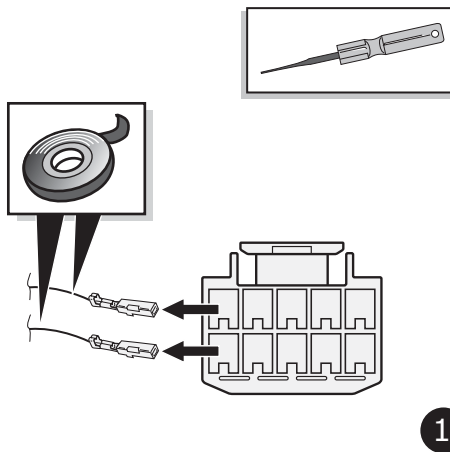
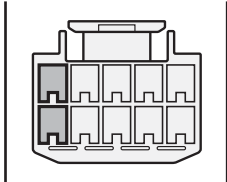

1

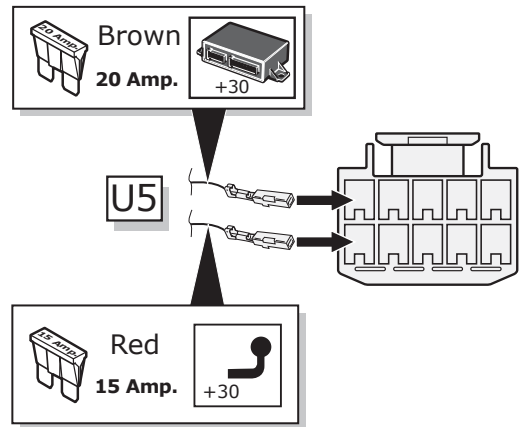

2

23

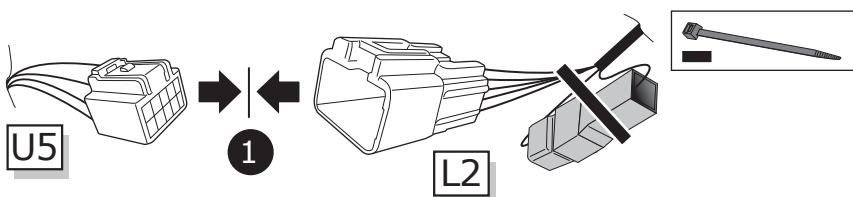

1

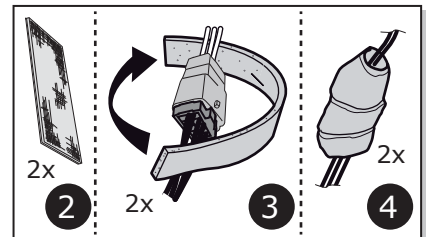

2

2x

3

4

2x

Option 2: Outlander PHEV 09/2013- & 2016-

24

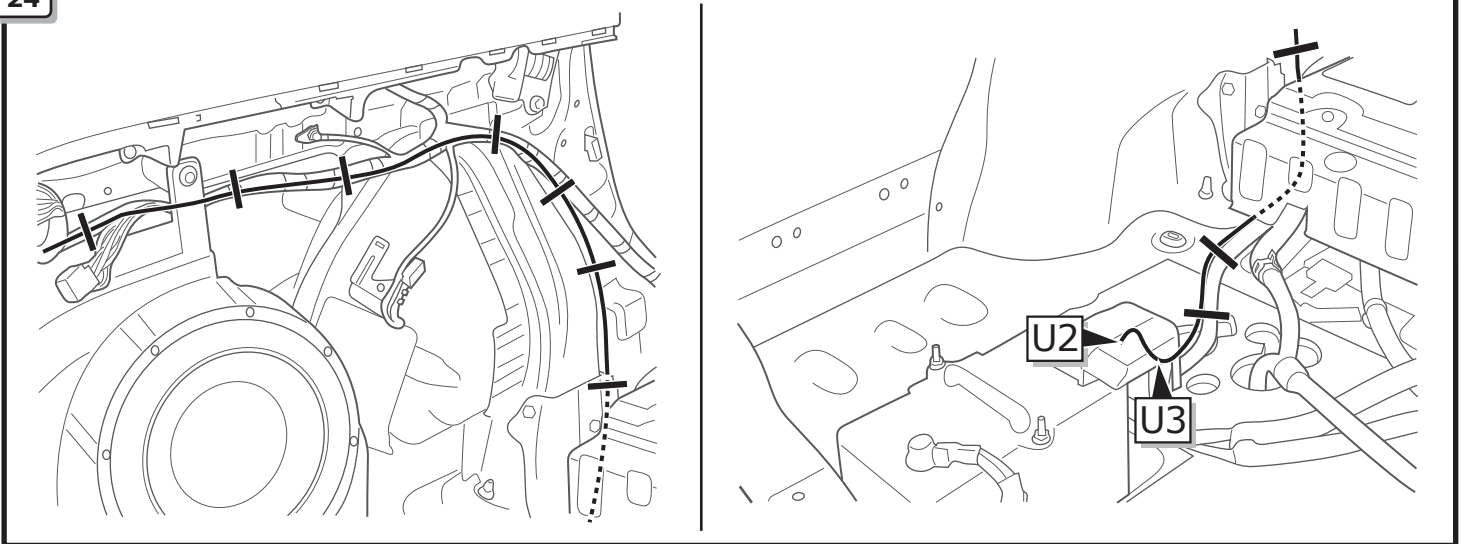

25

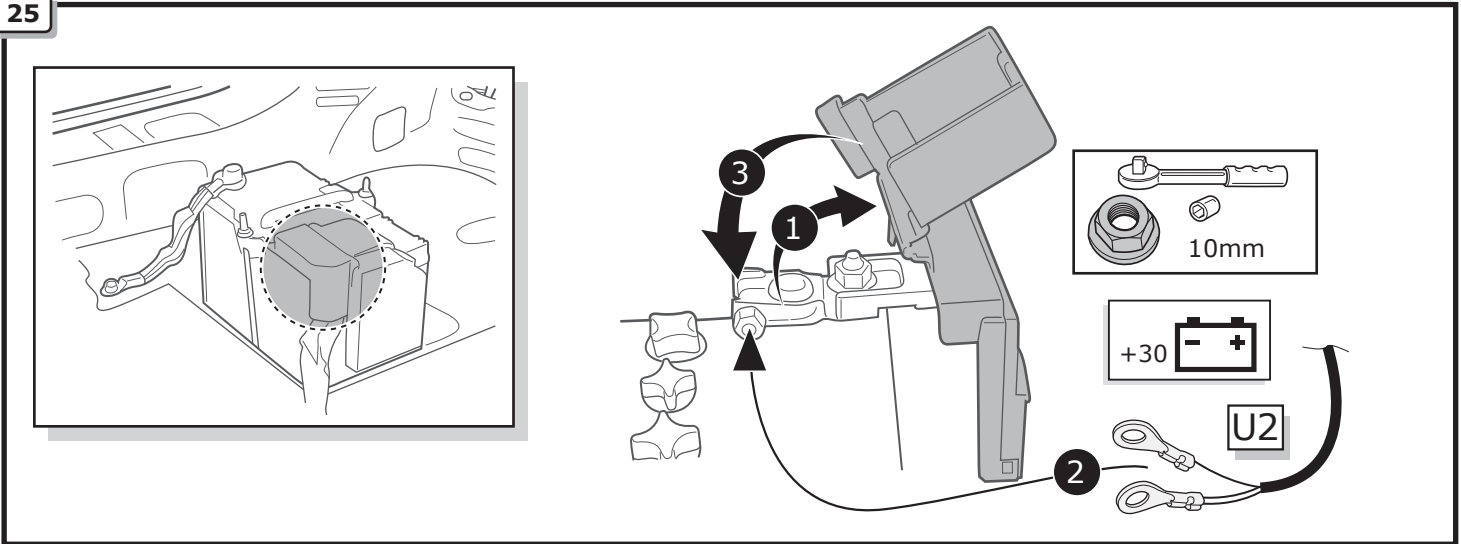

26

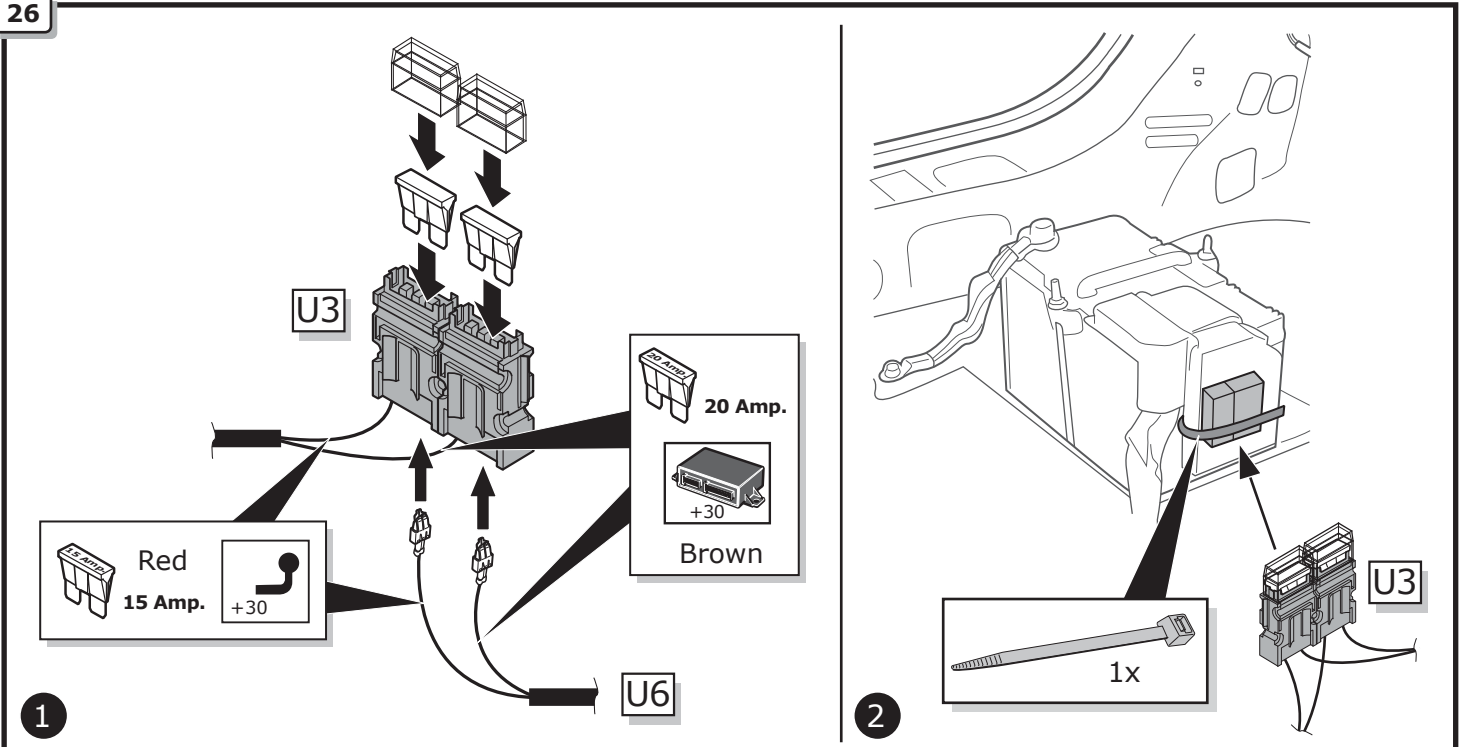

27

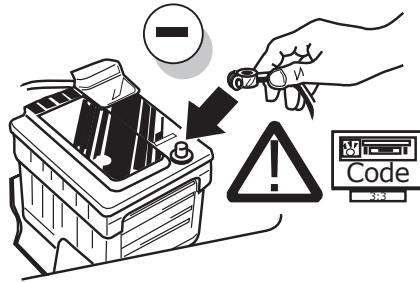

28

TEST ALL THE CIRCUITS WITH A TEST DEVICE WITH THE CORRECT POWER LOAD FOR EACH FUNCTION. A TEST DEVICE WITH LED'S CANNOT BE USED FOR THIS PURPOSE.

INFO

REINSTALL TRIM.

29

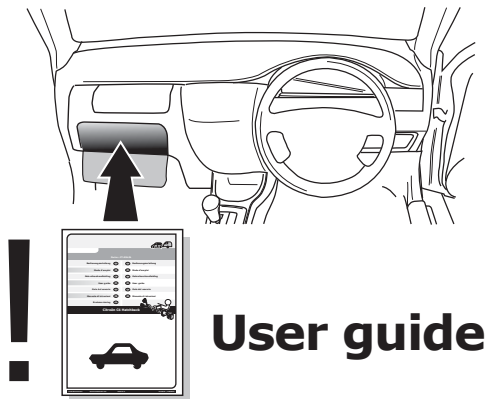

User guide

TECHNICAL SUPPORT

CALL 07440 202 052

ECS ELECTRONICS MONDAY TO FRIDAY
08.00 - 11.00 am
12.00 - 05.00 pm
ukts@ecs-electronics.com
www.ecs-electronicsuk.co.uk

SOCKET CONNECTION

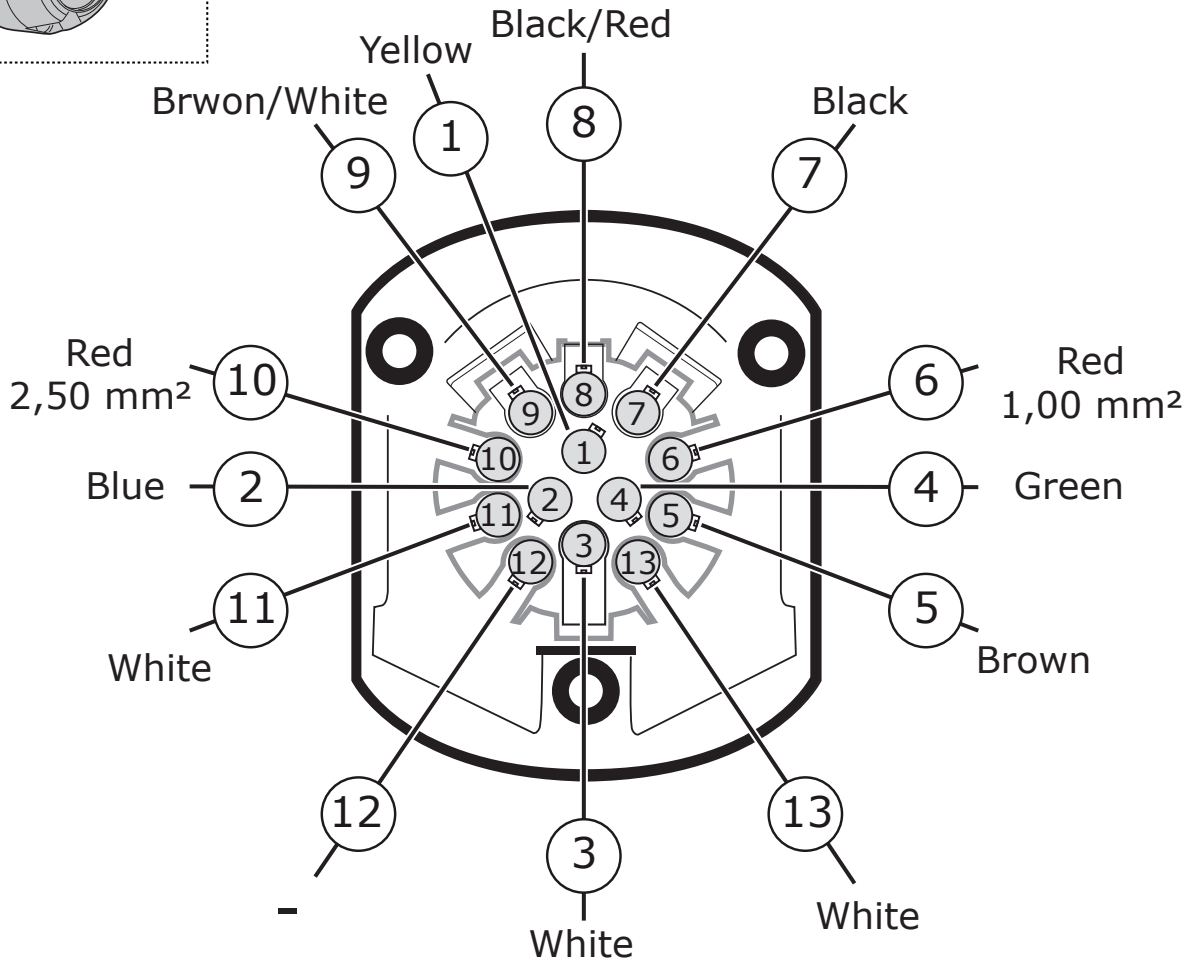
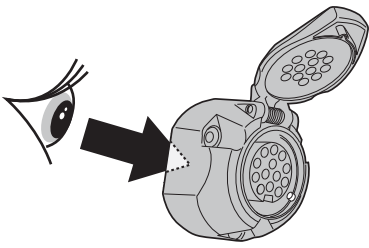

Socket connection

DIN/ISO 11446													
	1/L	2	3/31	4/R	5/58-R	6/54	7/58-L	8	9	10	11	12	13
Pmax	21W	21W		21W	52W	3x21W	52W	21W	180W/15Amp	180W/15Amp			
	Yellow	Blue	White	Green	Brown	Red 1,00 mm ²	Black	Black/Red	Brown/White	Red 2,50 mm ²	White	-	White