

## Skoda Rapid HB Skoda Rapid Spaceback Seat Toledo HB 2013-

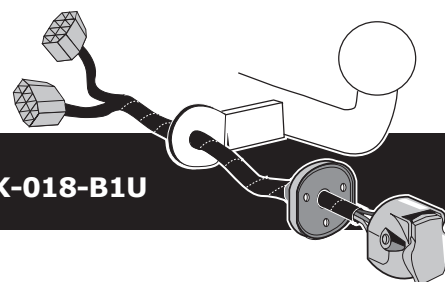

Partnr.: SK-018-B1U

- Fitting instructions electric wiring kit tow bar with 12-N socket up to DIN/ISO Norm 1724.
- We would expressly point out that assembly not carried out properly by a competent installer will result in cancellation of any right to damage compensation, in particular those arising by virtue of the product liability act.
- Contents of these kits and their fitting manuals are subject to alteration without notice, please ensure that these instructions are read and fully understood before commencing installation.
- Do not overload circuits; the maximum loads per connection are detailed in this manual.
- Attention! Before Installation, please read this manual carefully and inform your customer to consult the vehicle owners manual to check for any vehicle modifications required before towing.
- In the event of functional problems, troubleshooting must be limited to about 0.5 hours, contact the technical support:  
[t.skinner@ecs-electronics.com](mailto:t.skinner@ecs-electronics.com) / 07440 202 052.



# Part list

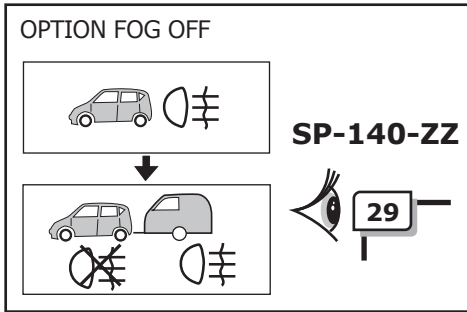
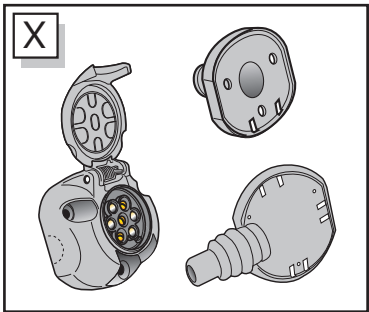
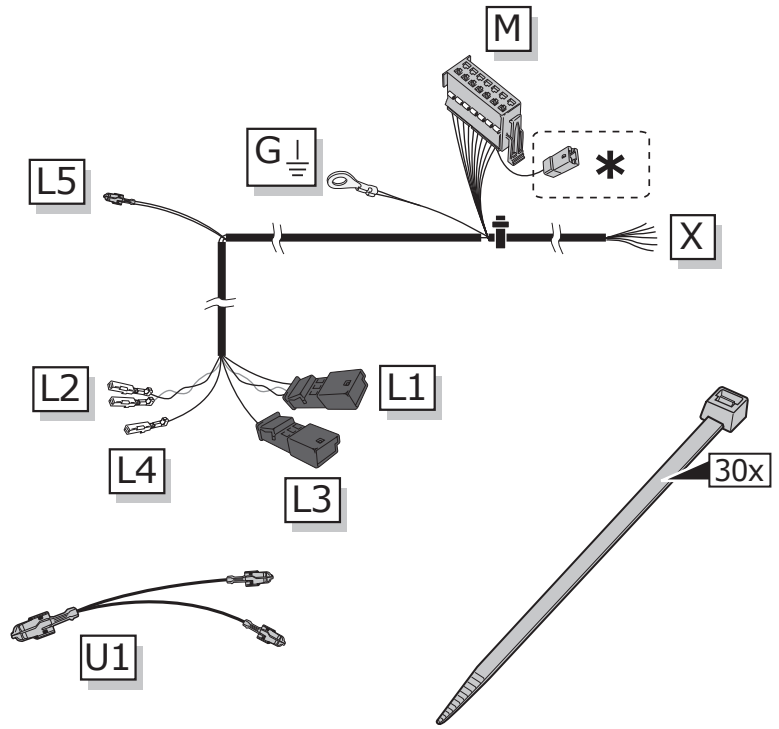
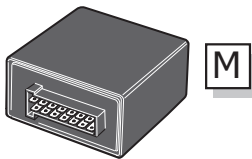
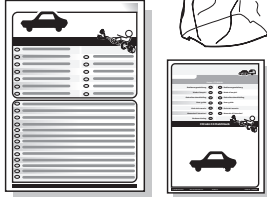
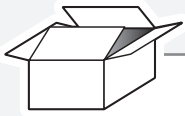

\* Reverse signal preparation  
**Pag. 17**

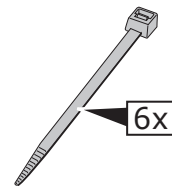
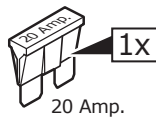
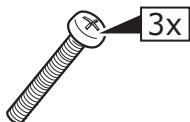

**ROUTING**

Skoda Rapid HB / Seat Toledo HB

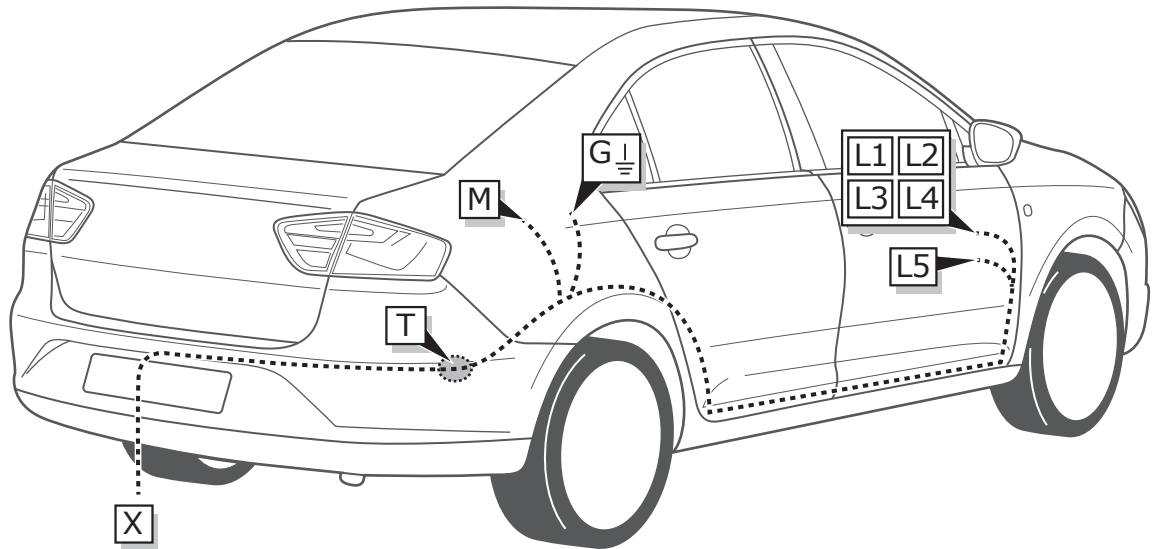

**ROUTING**

Skoda Rapid Spaceback

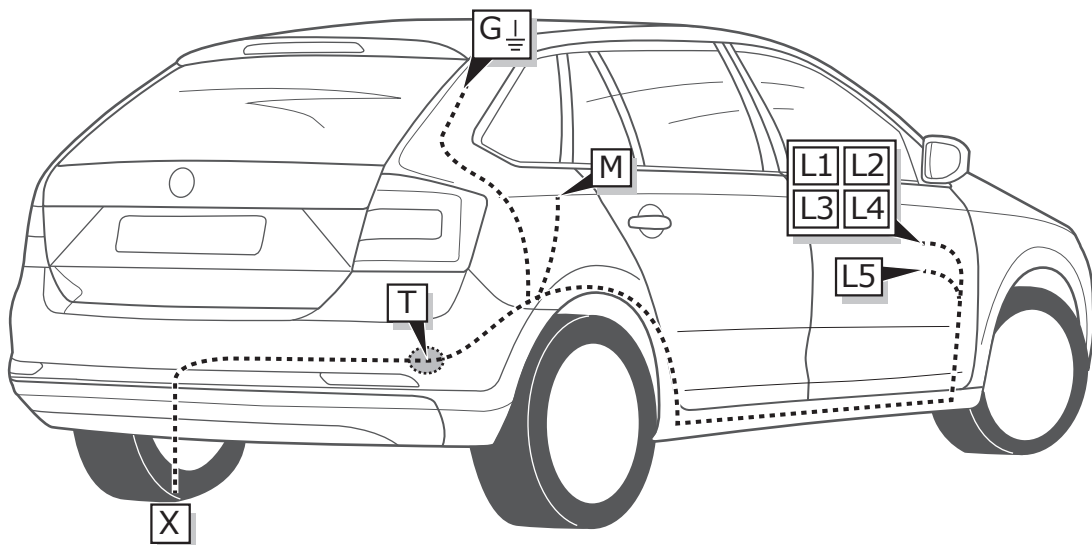

1

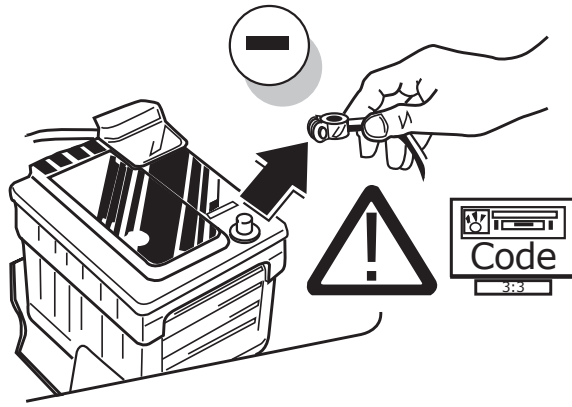

2

Skoda Rapid HB / Seat Toledo HB

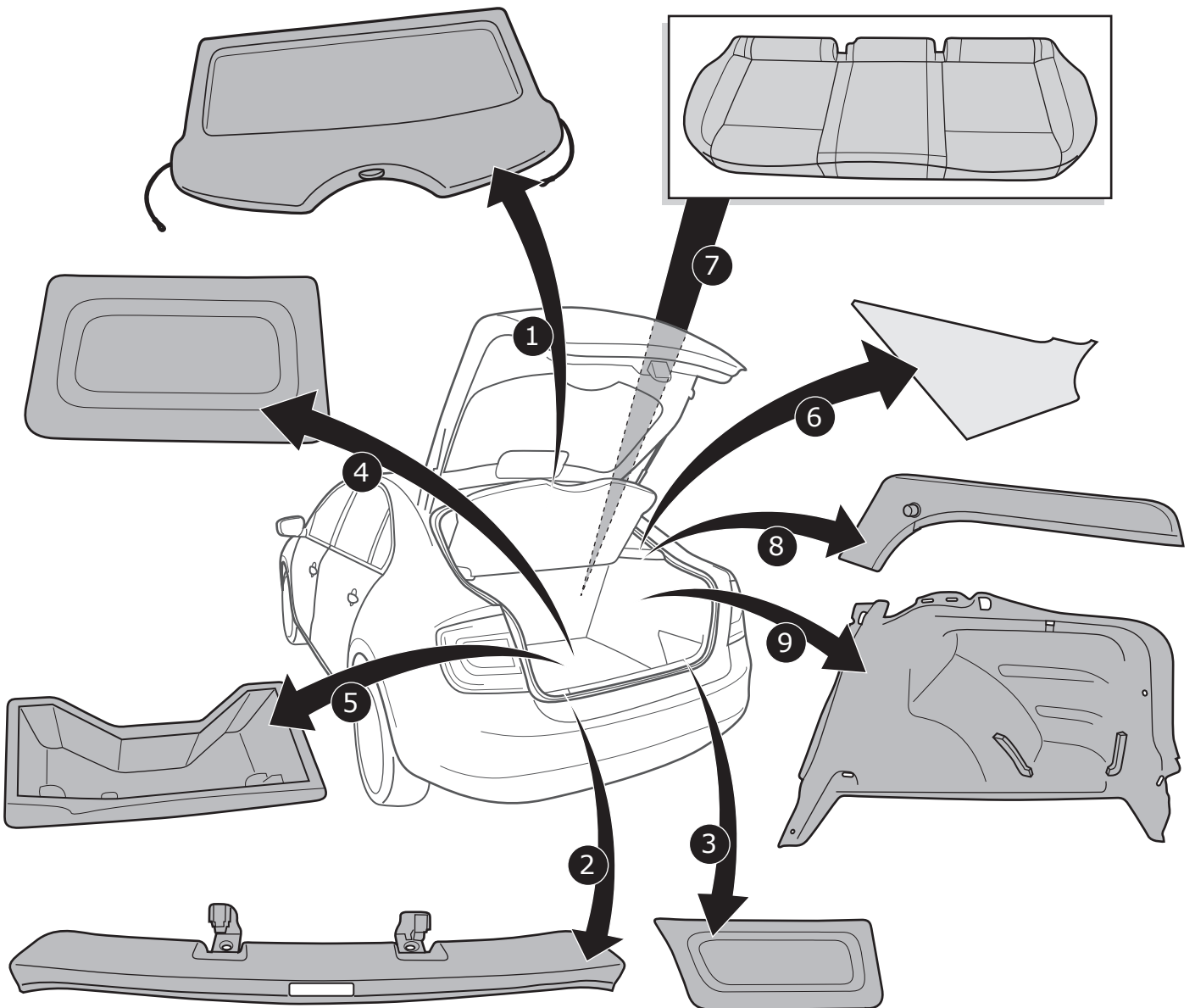

2.1

All models

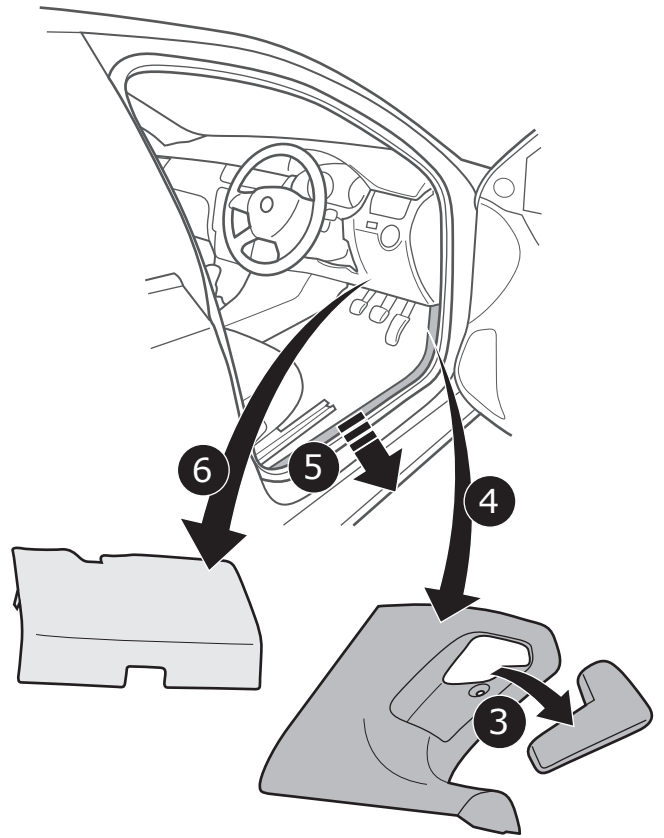
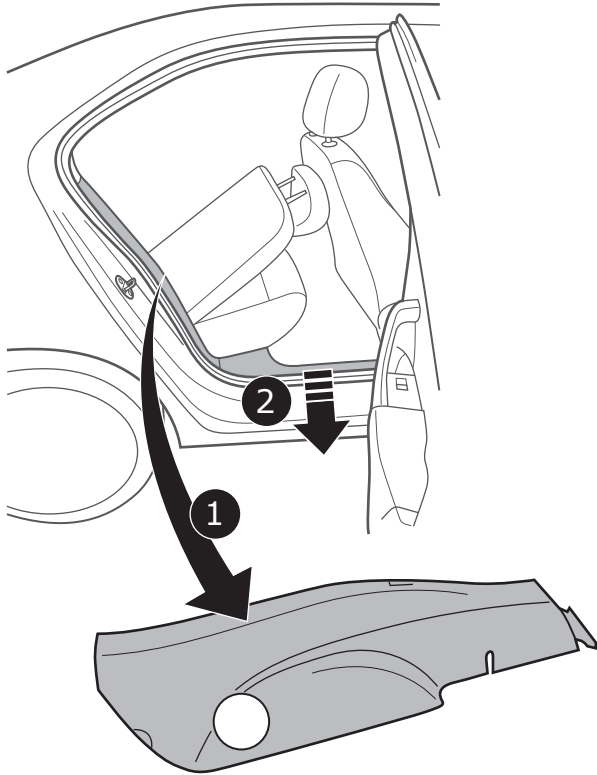

2.2

Skoda Rapid Spaceback

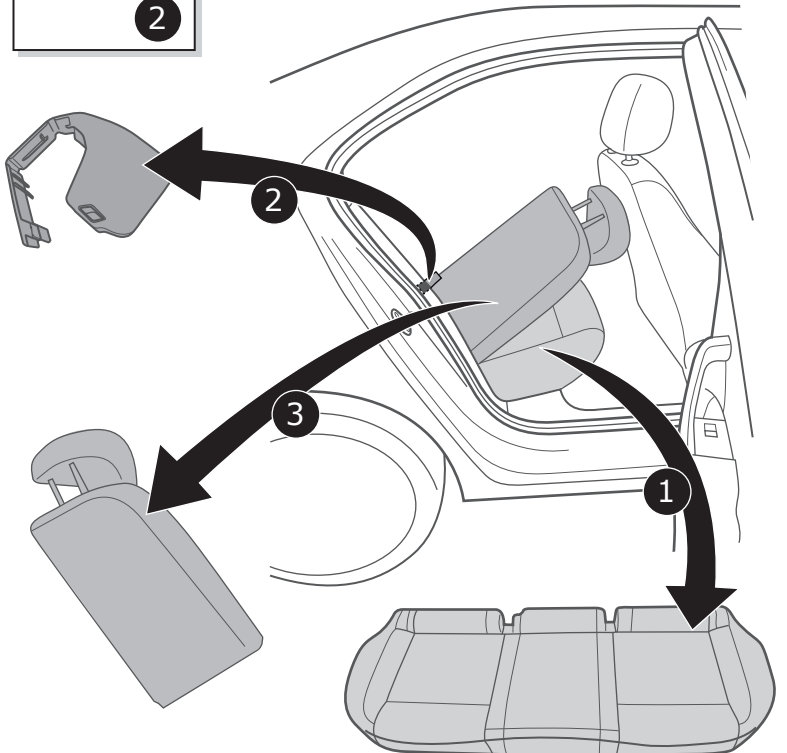
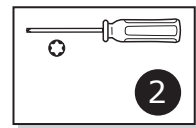
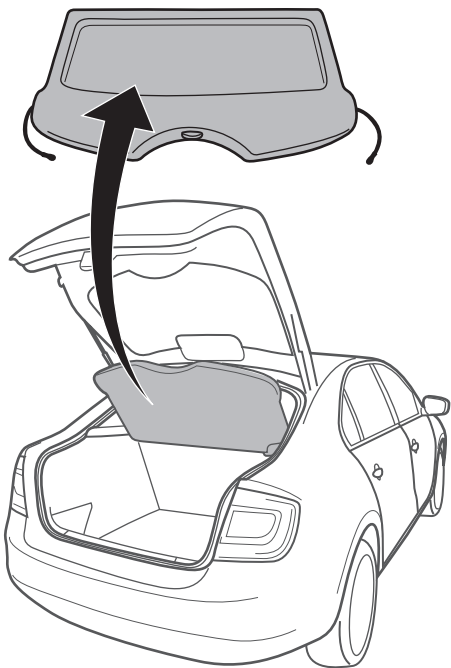

Skoda Rapid Spaceback

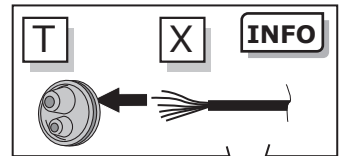
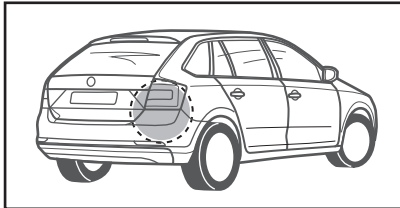
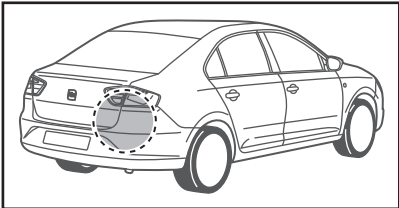
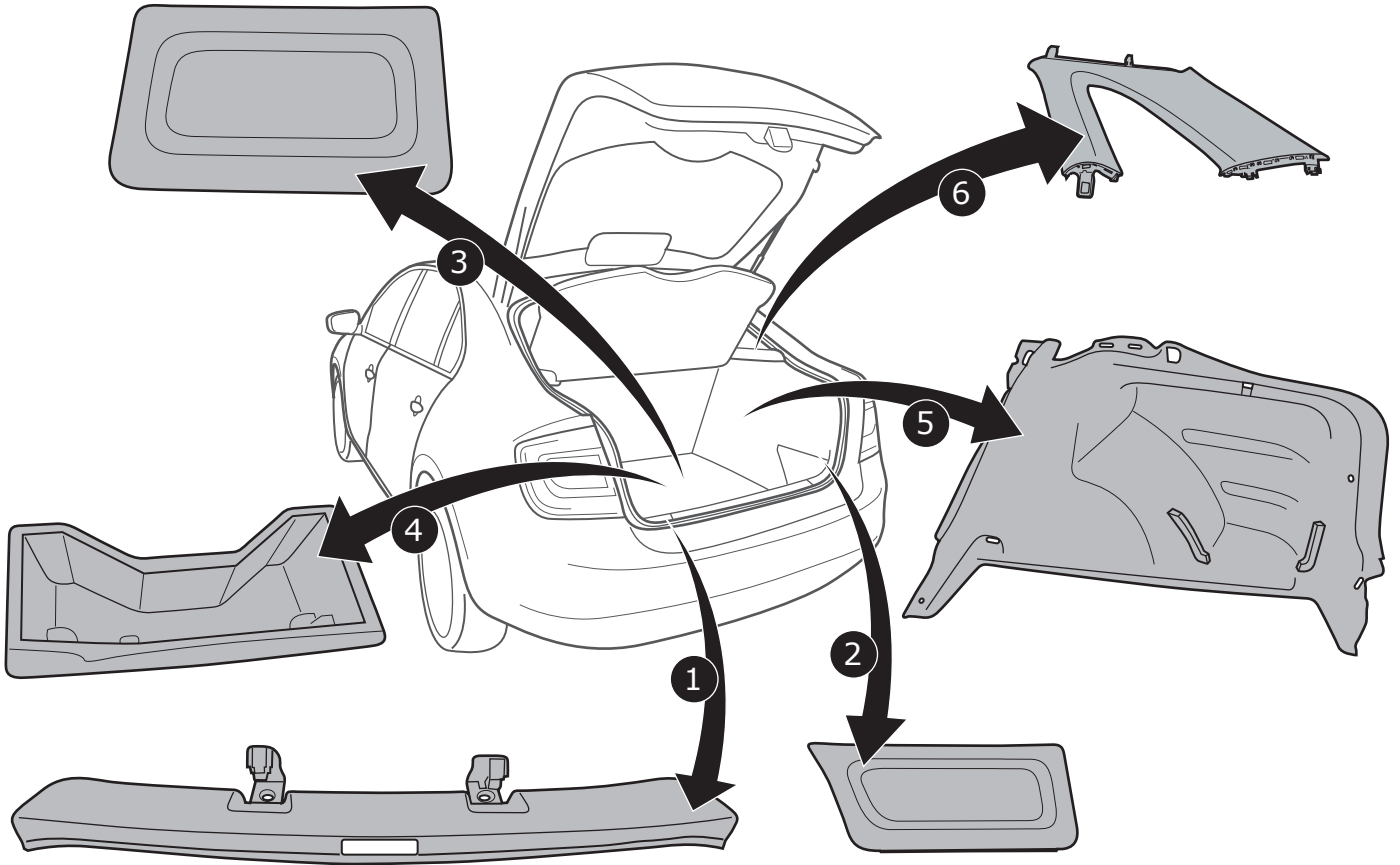

Option 1

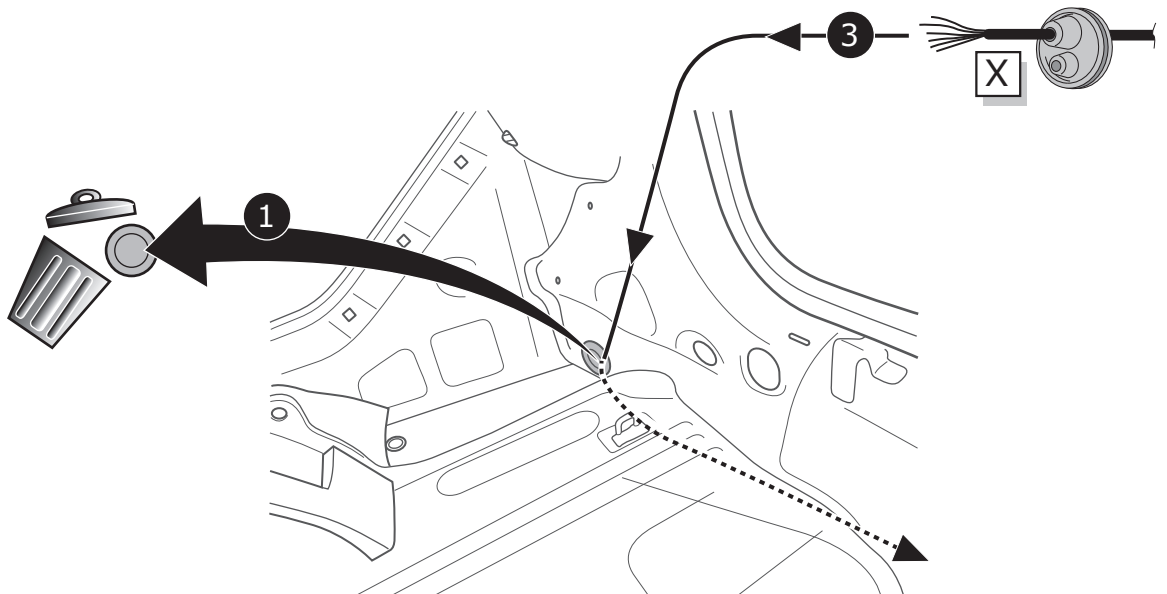

3.1

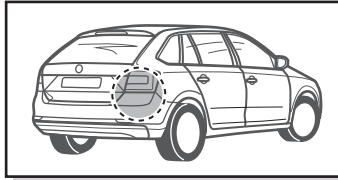
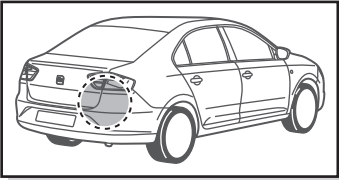

Option 2

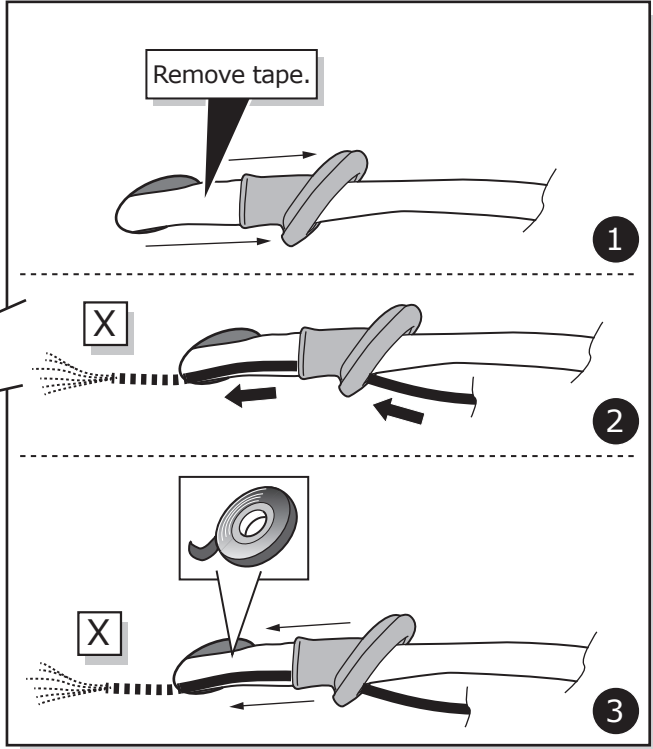
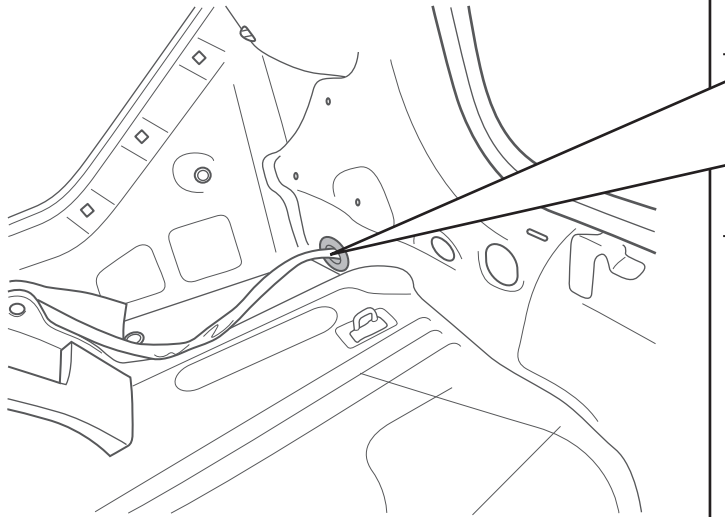

A

Option 1

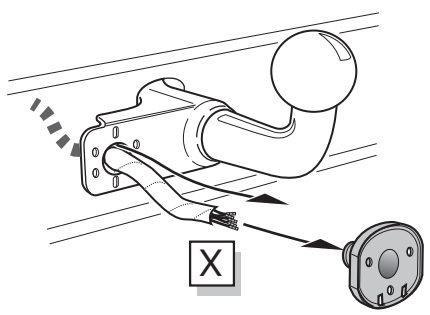

Option 2

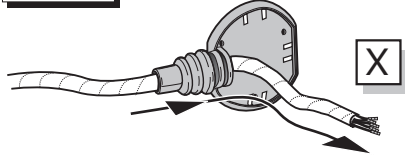

Option 3

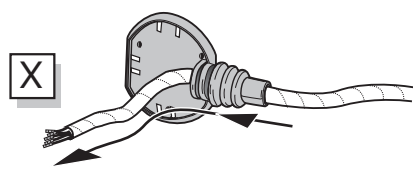

INFO

SOCKET CONNECTION



B

Option 1

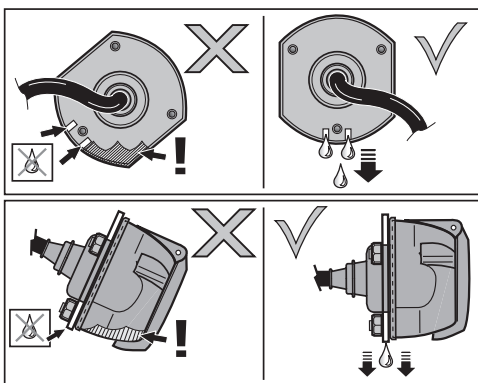
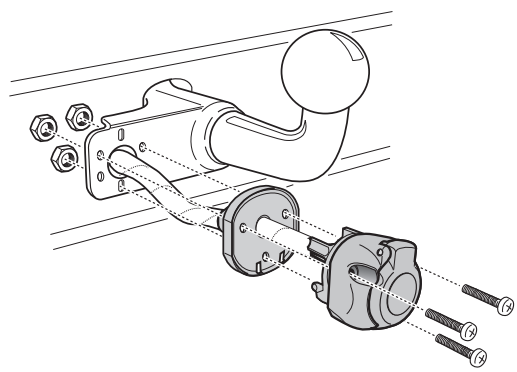

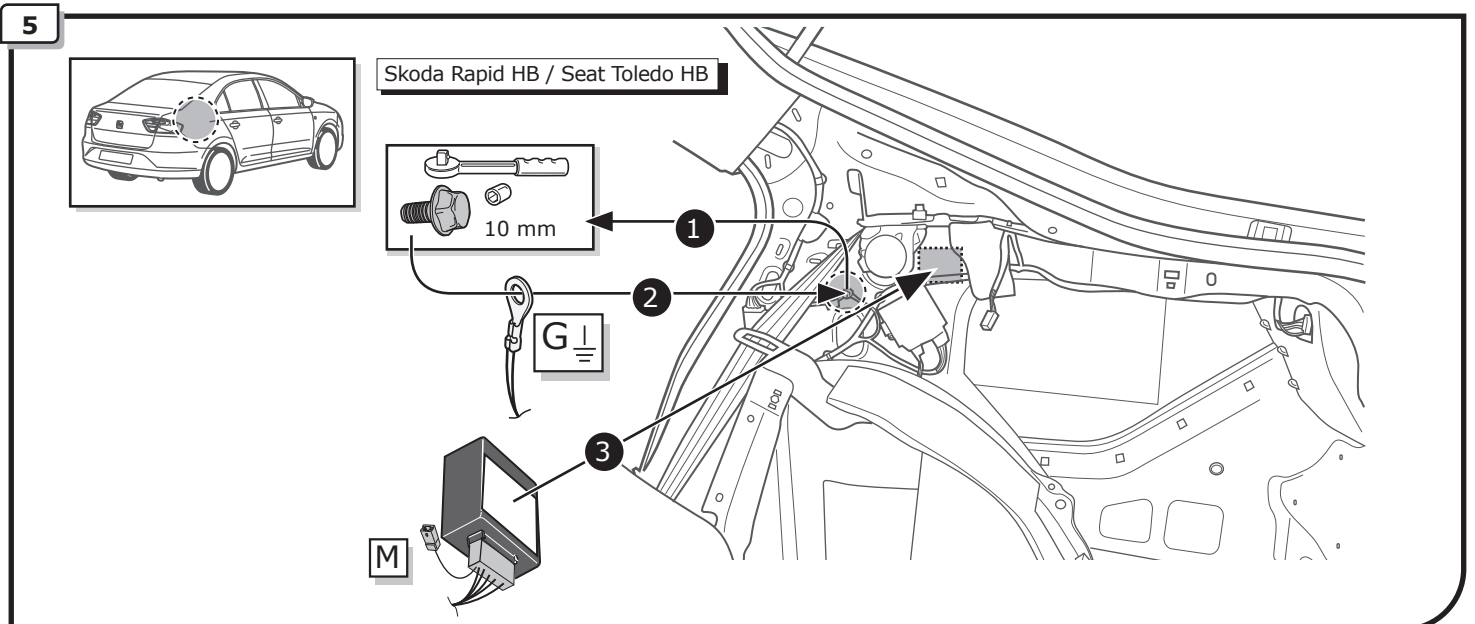
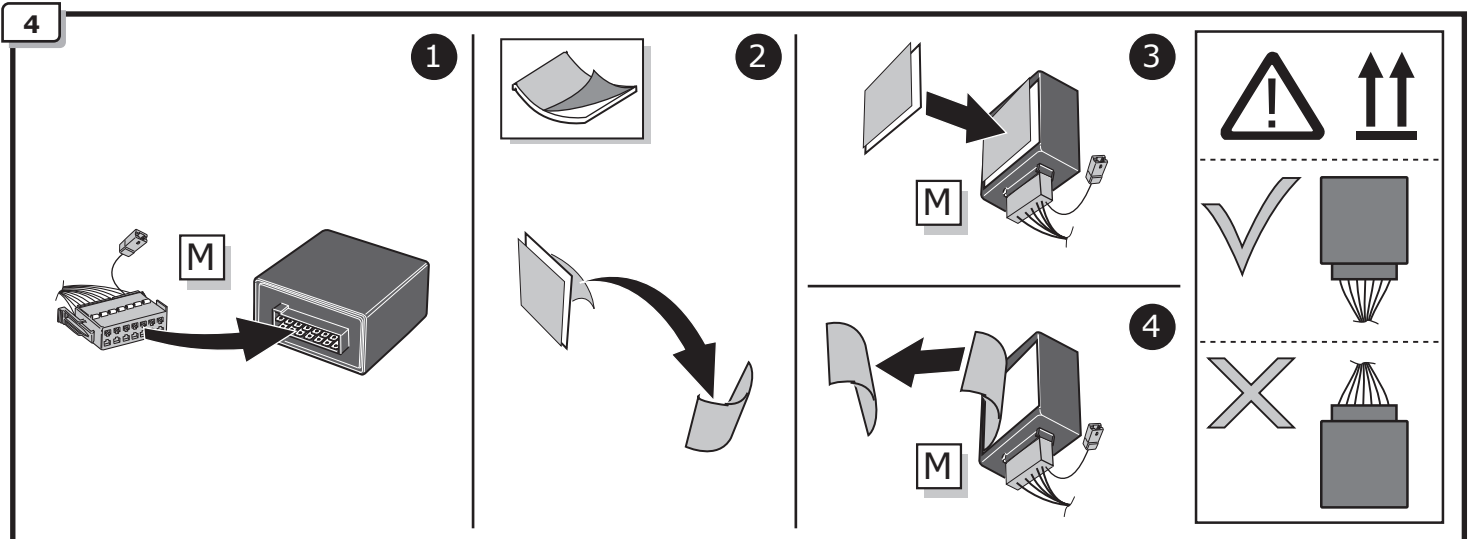
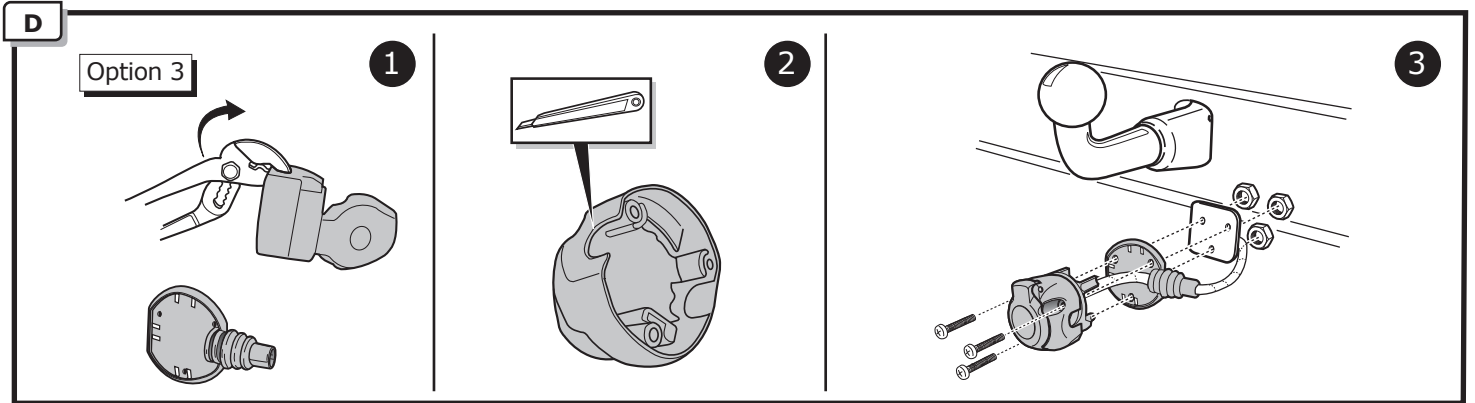
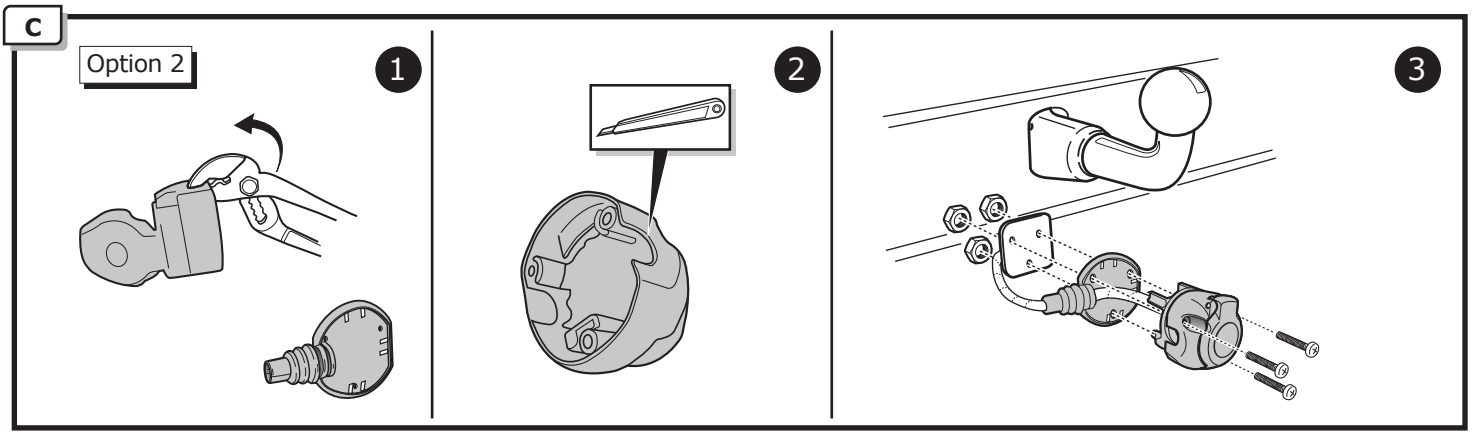



5.1

Skoda Rapid Spaceback

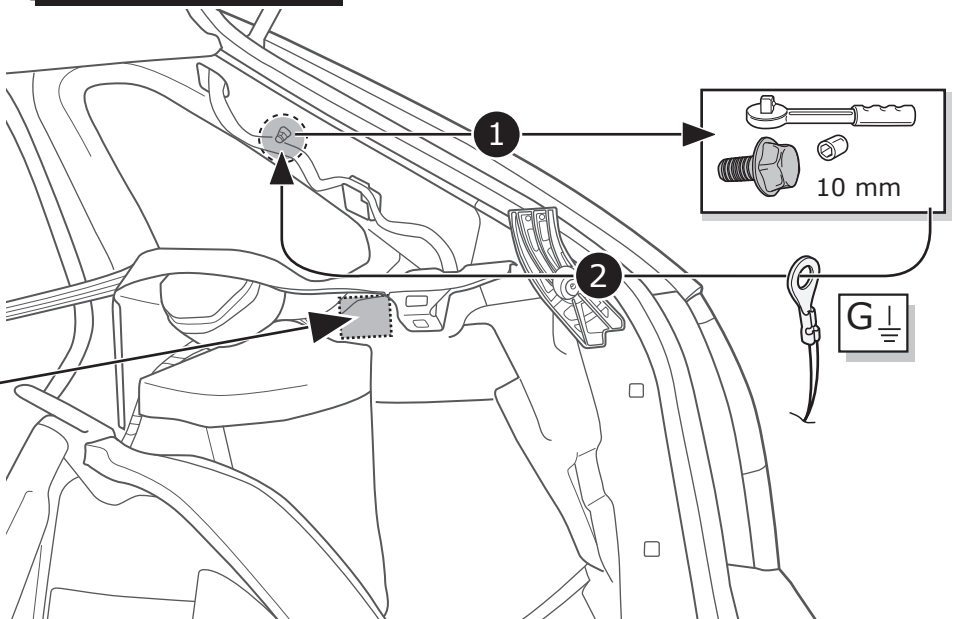
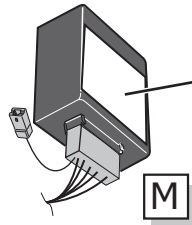
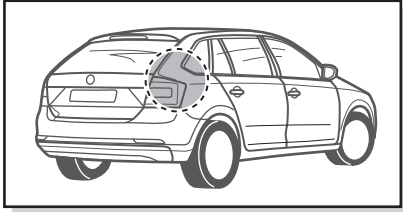

6

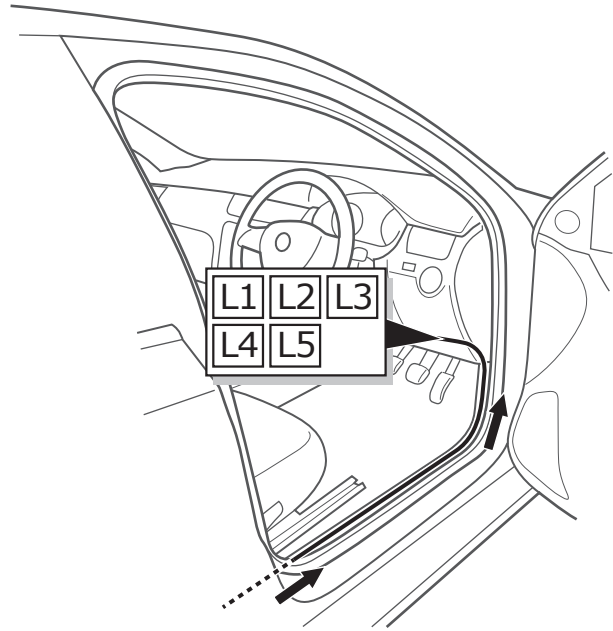
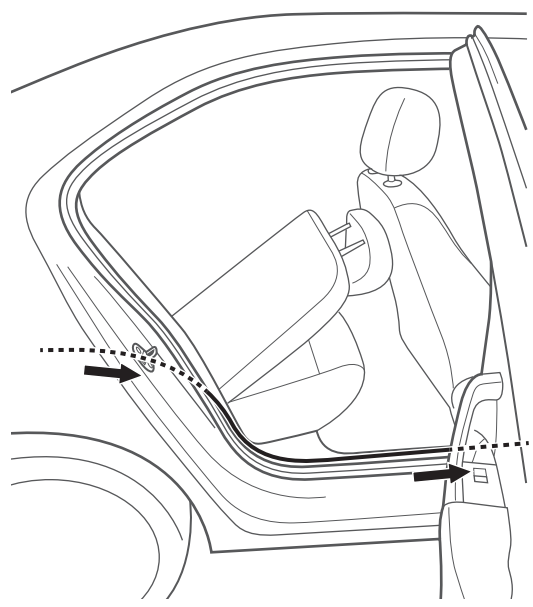

7

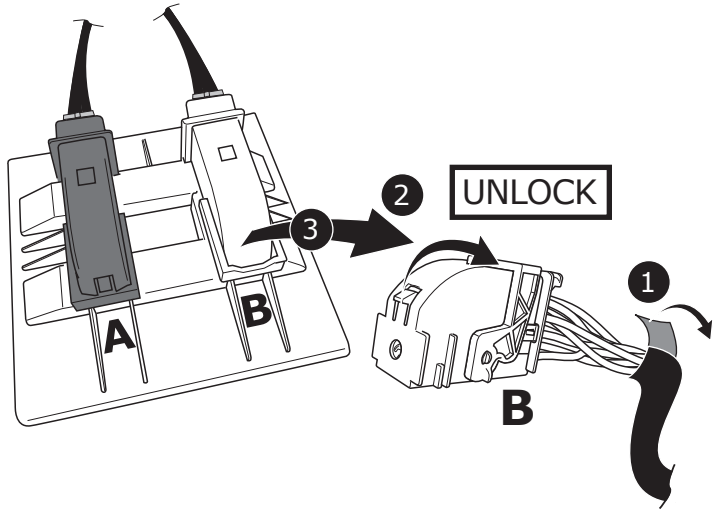
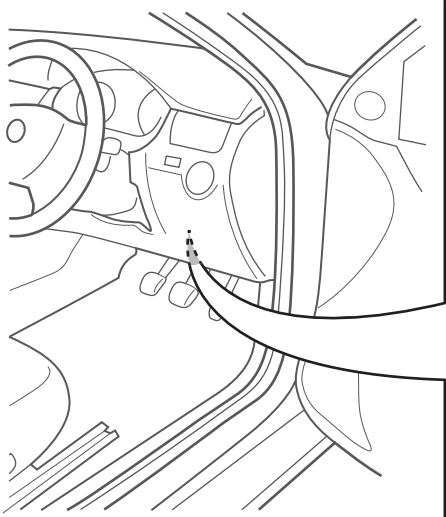

8

1

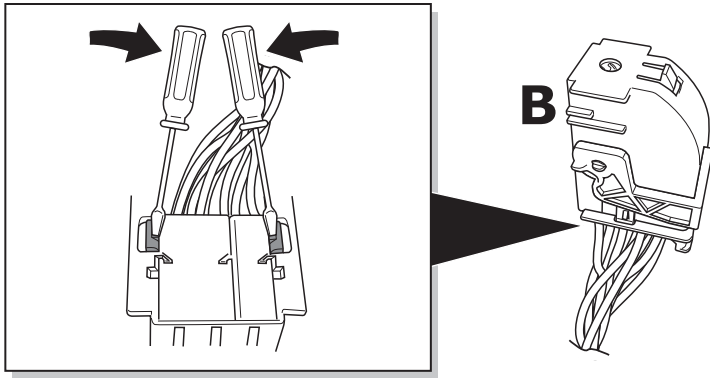

2

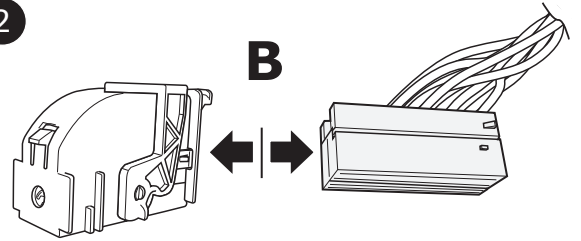

3

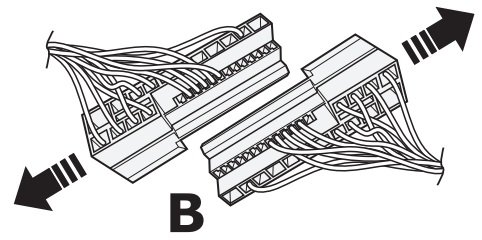

9

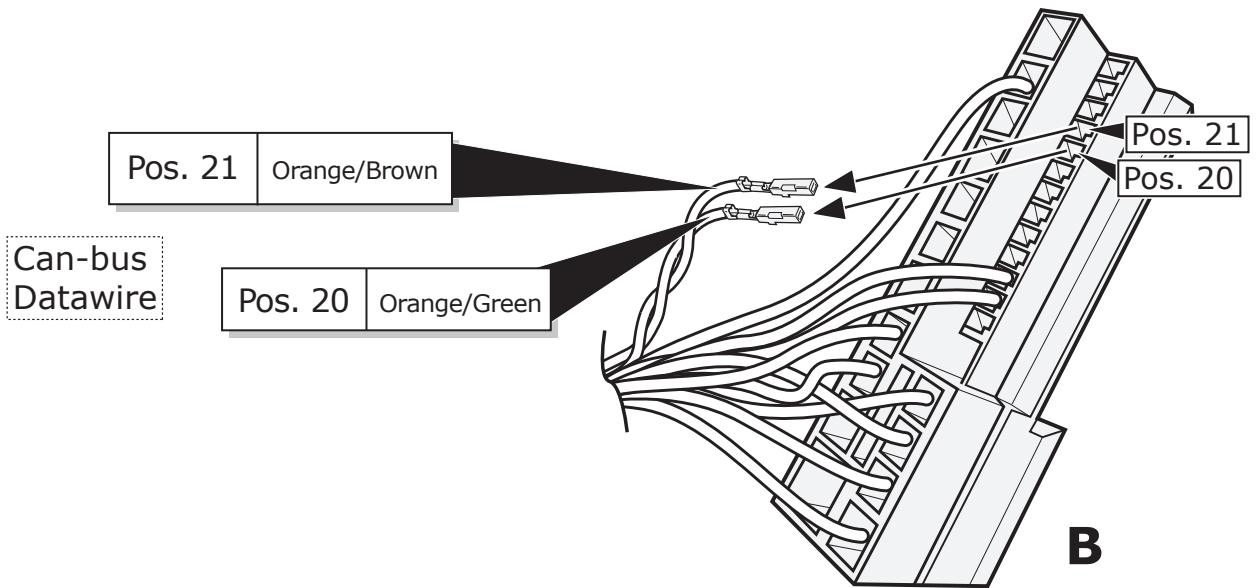

10

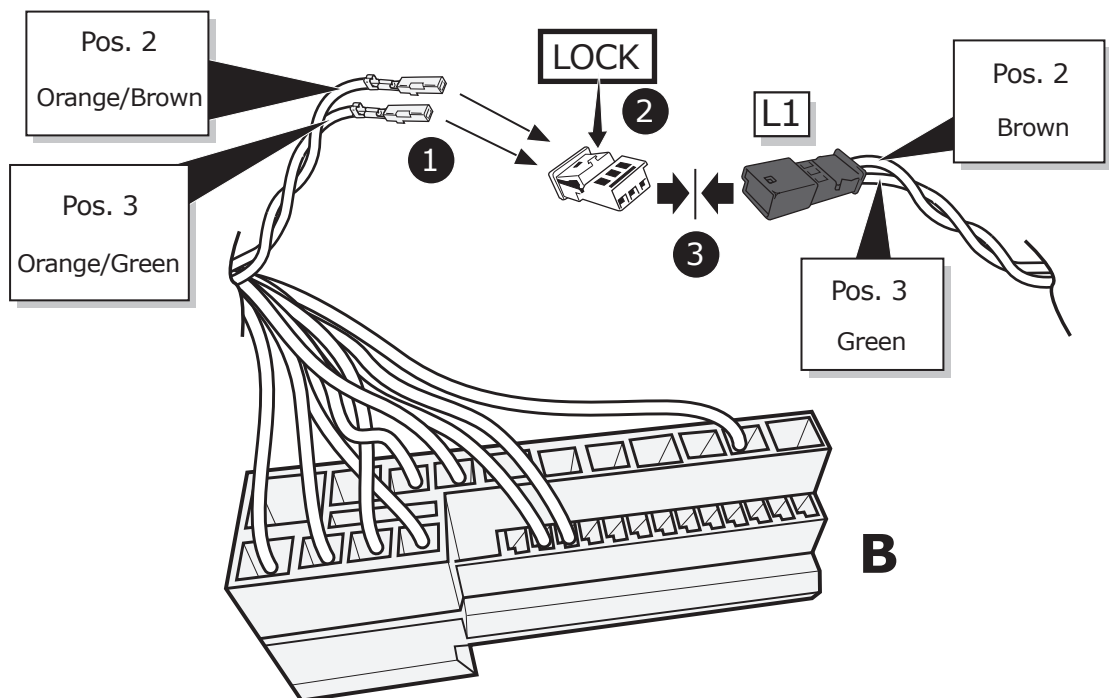

11

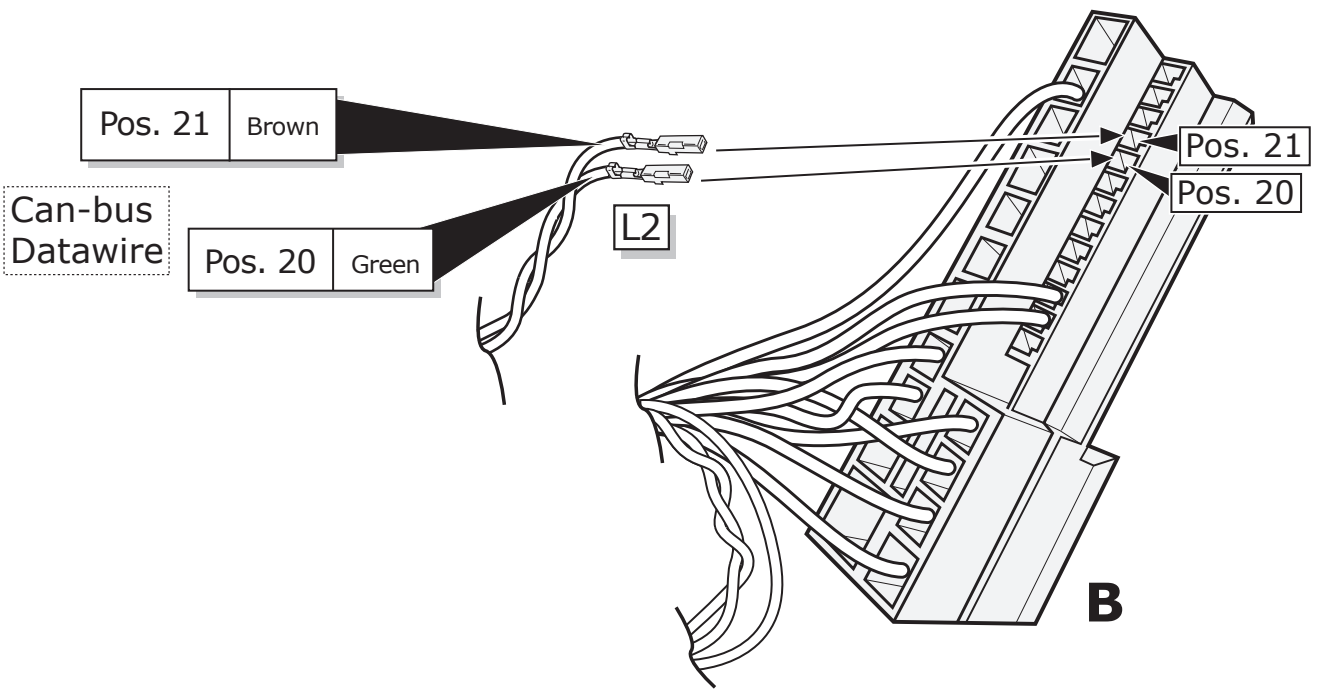

12

1

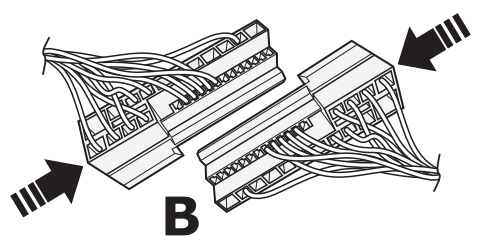

2

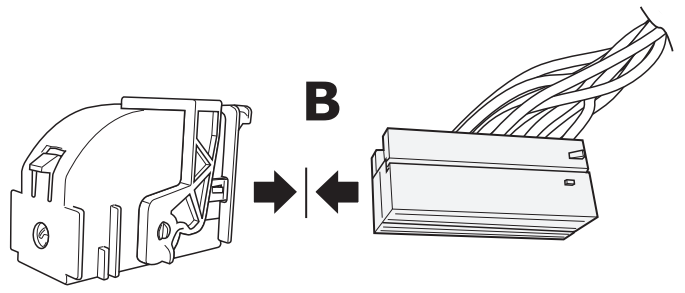

13

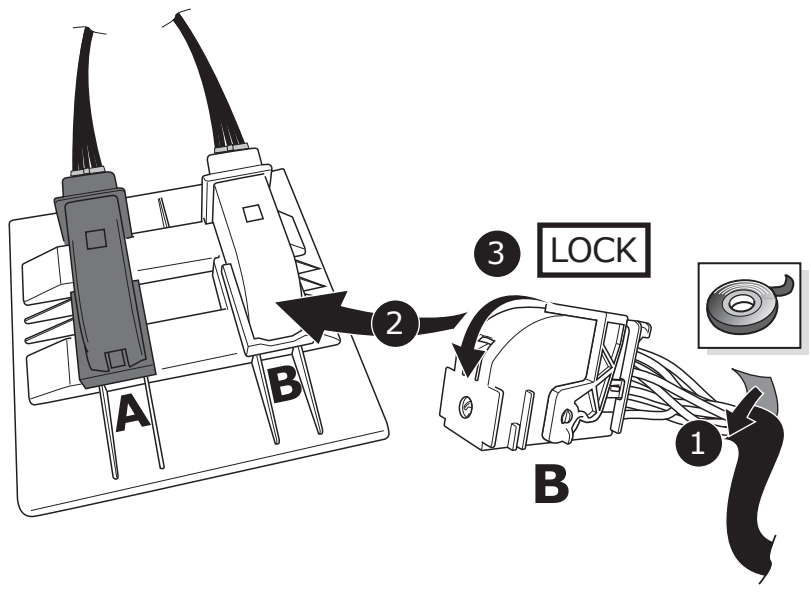
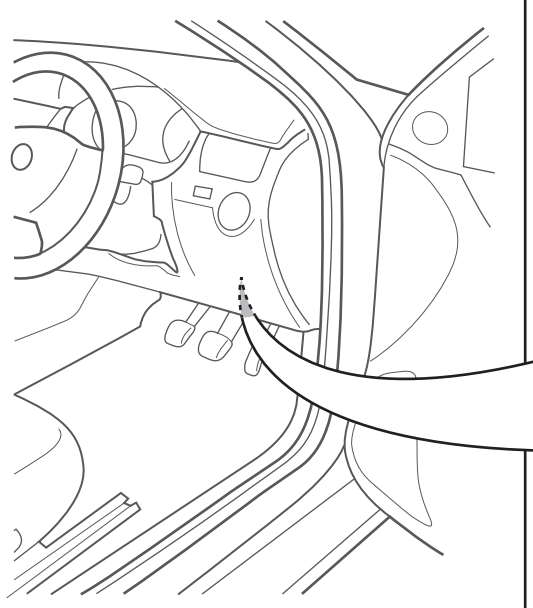

14

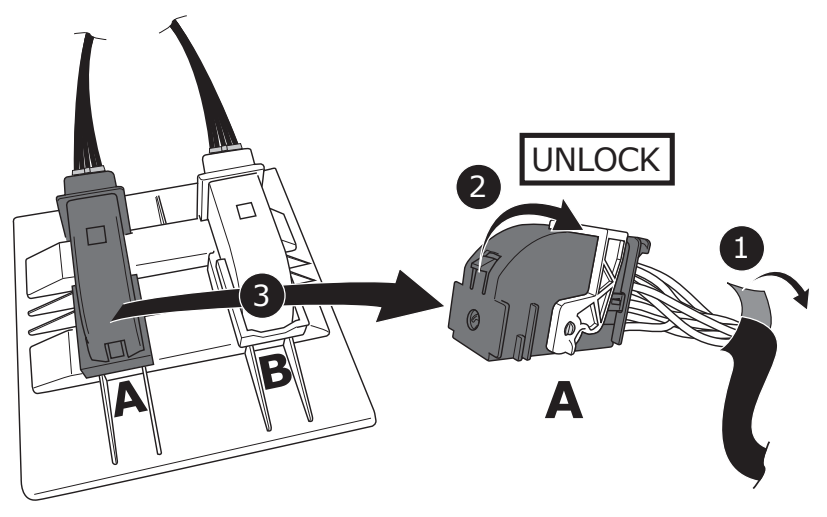
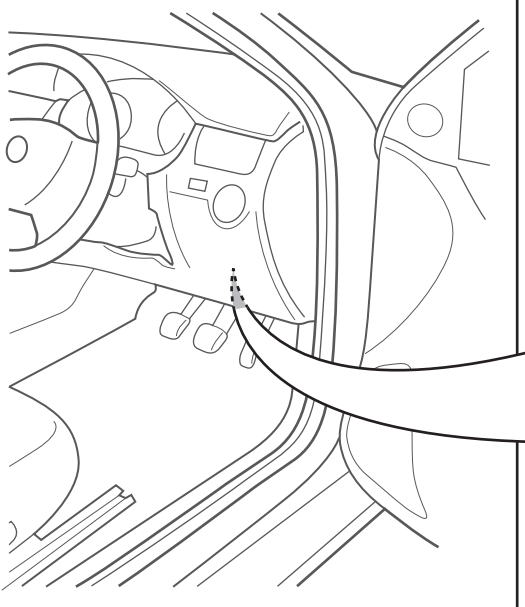

15

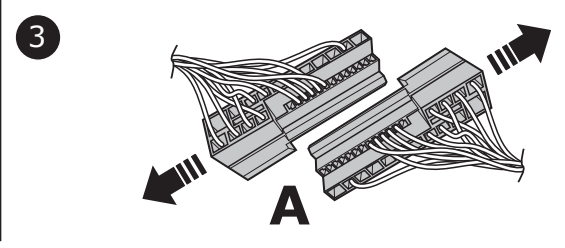
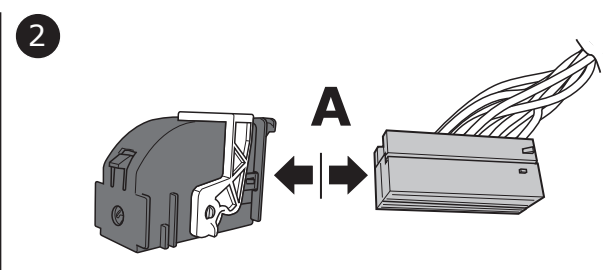
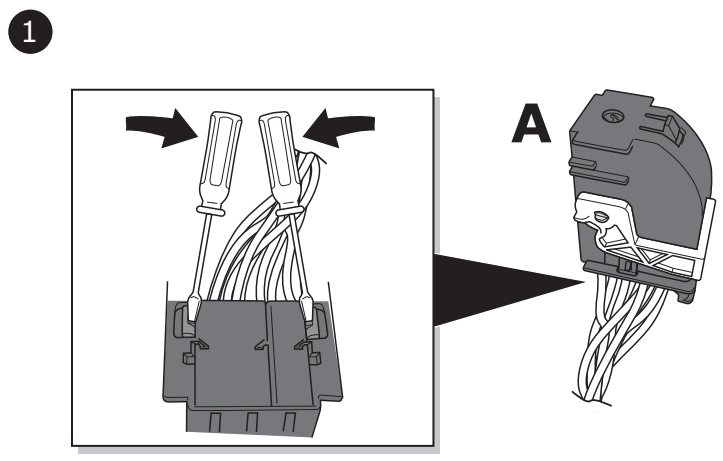

16

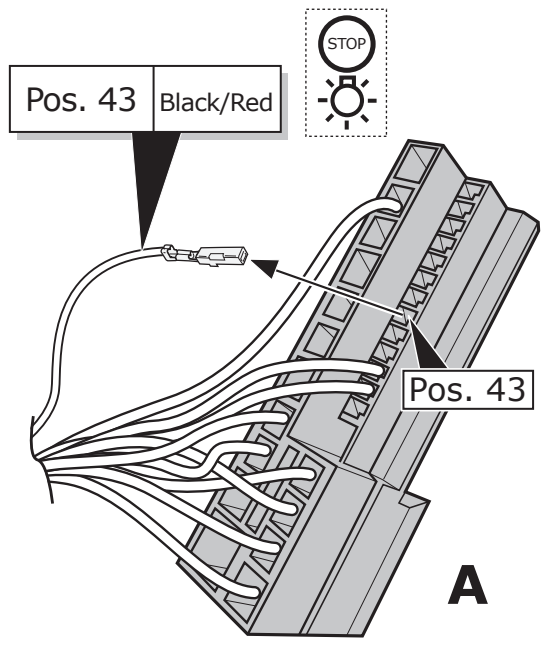

17

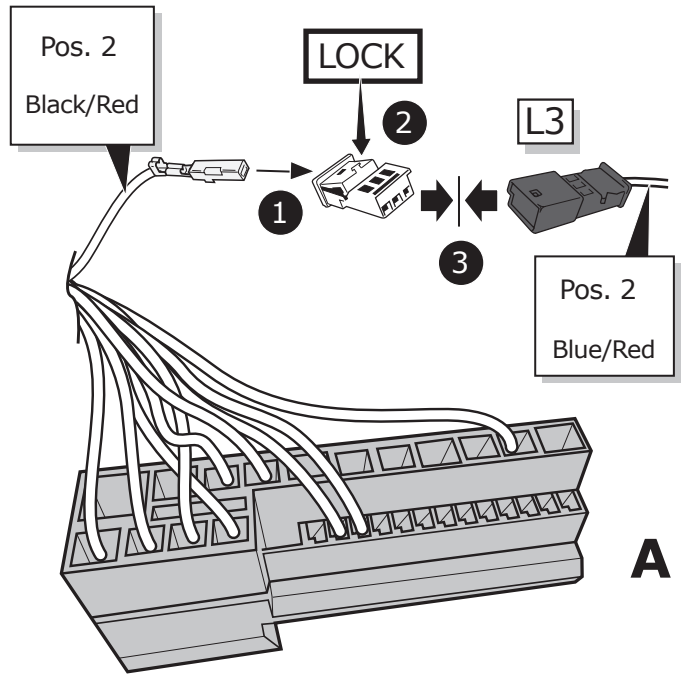

18

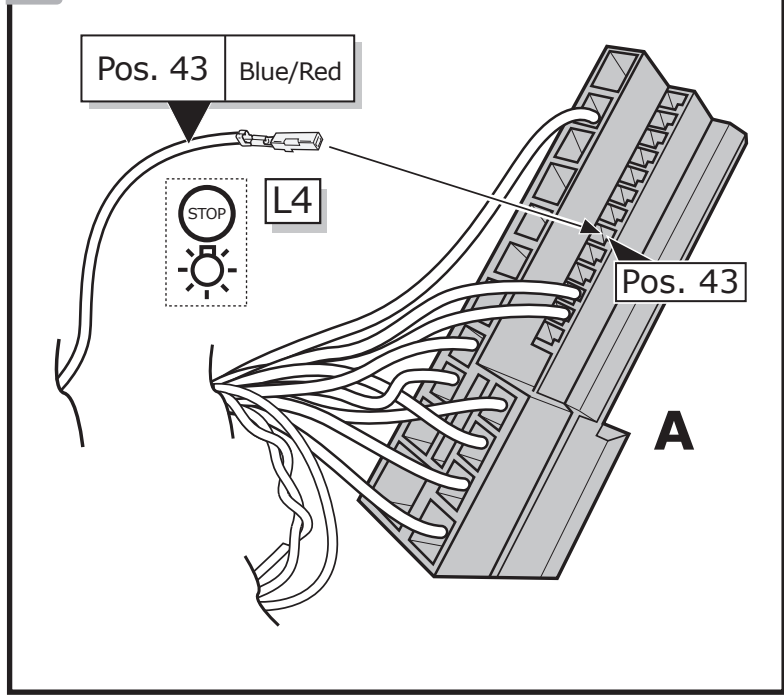

19

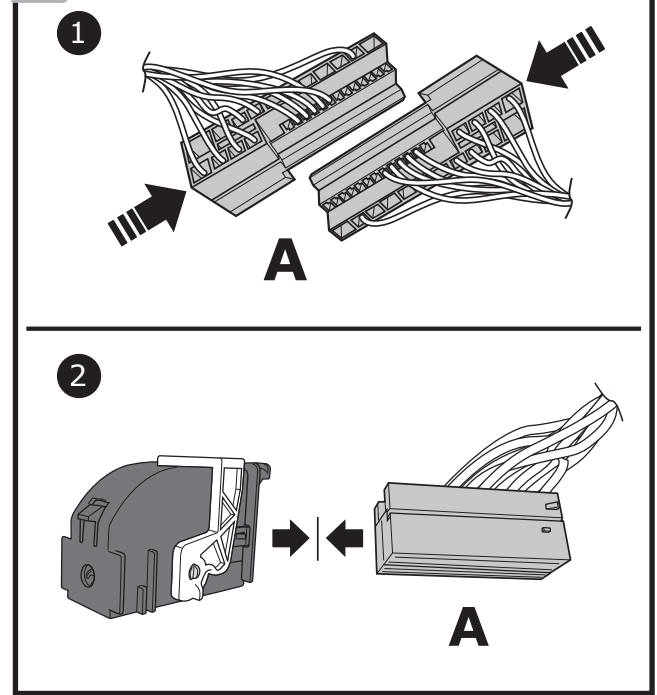

20

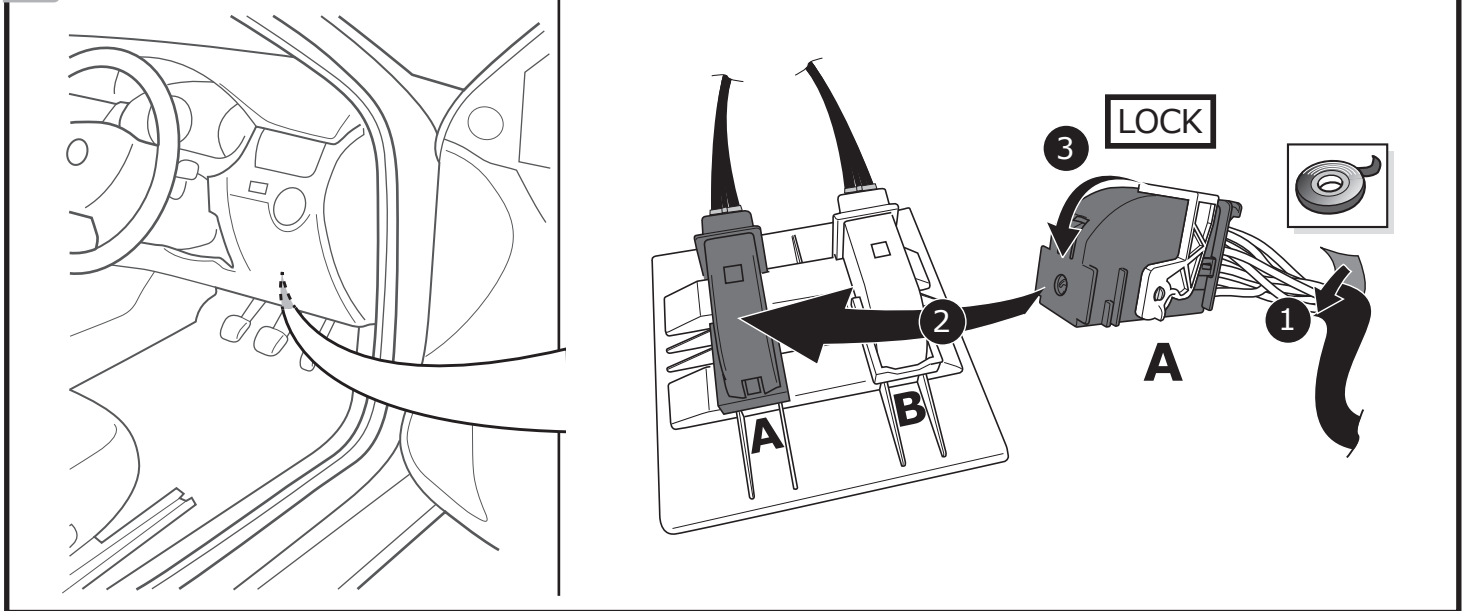

21

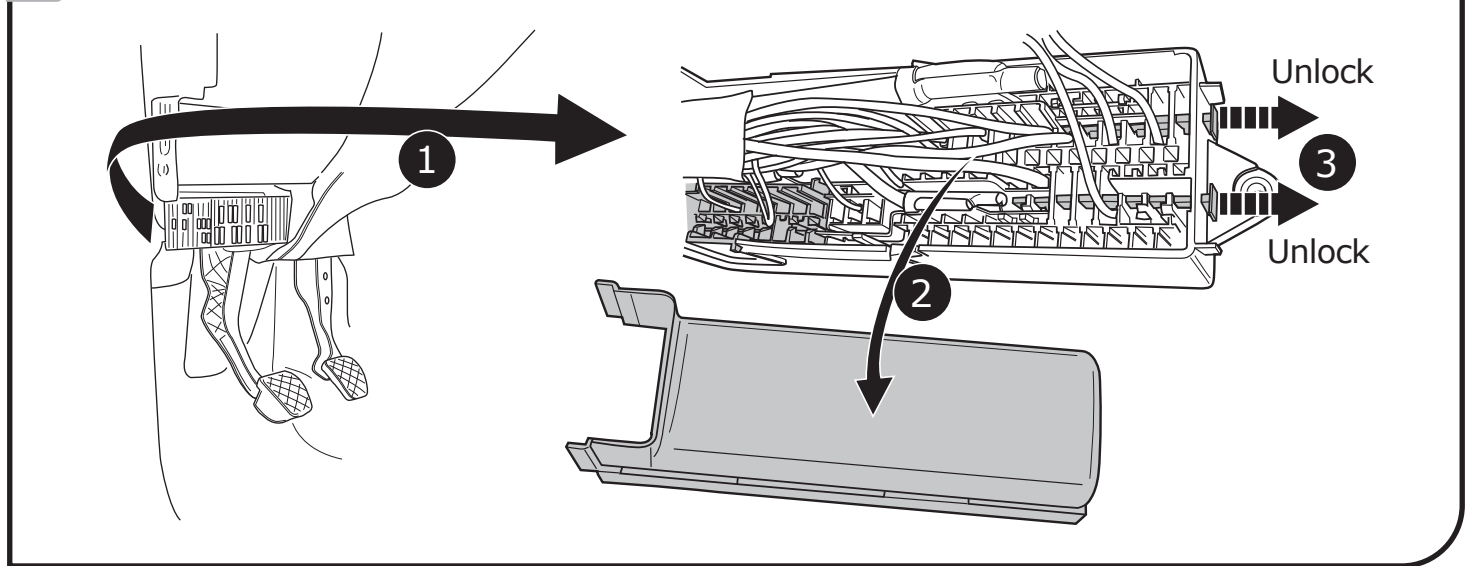

22

+15

+30

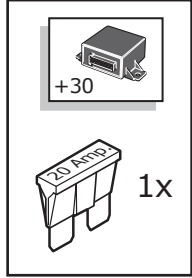

2

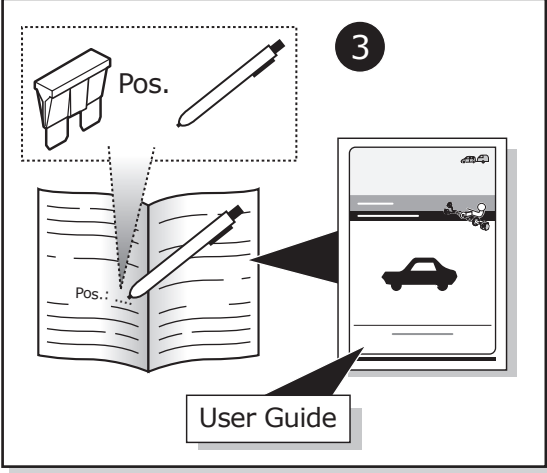

3

L5

Orange

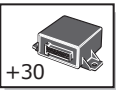

1

23

If positions are taken

1

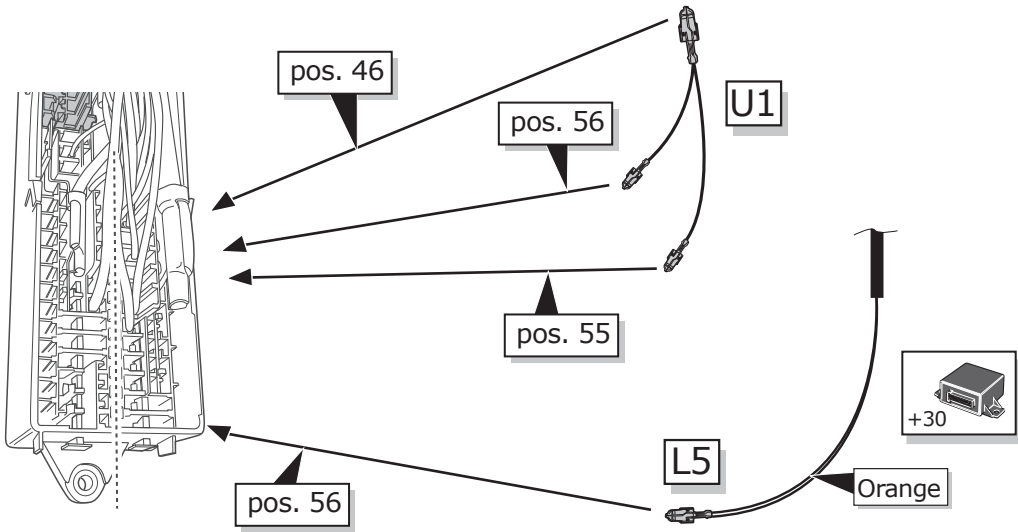

2

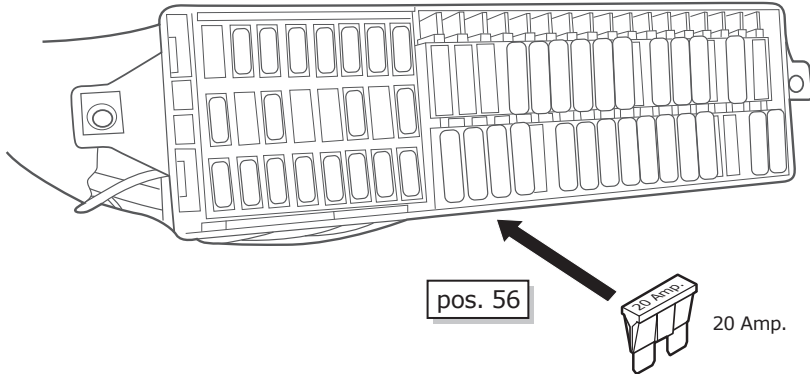

pos. 56



20 Amp.

24

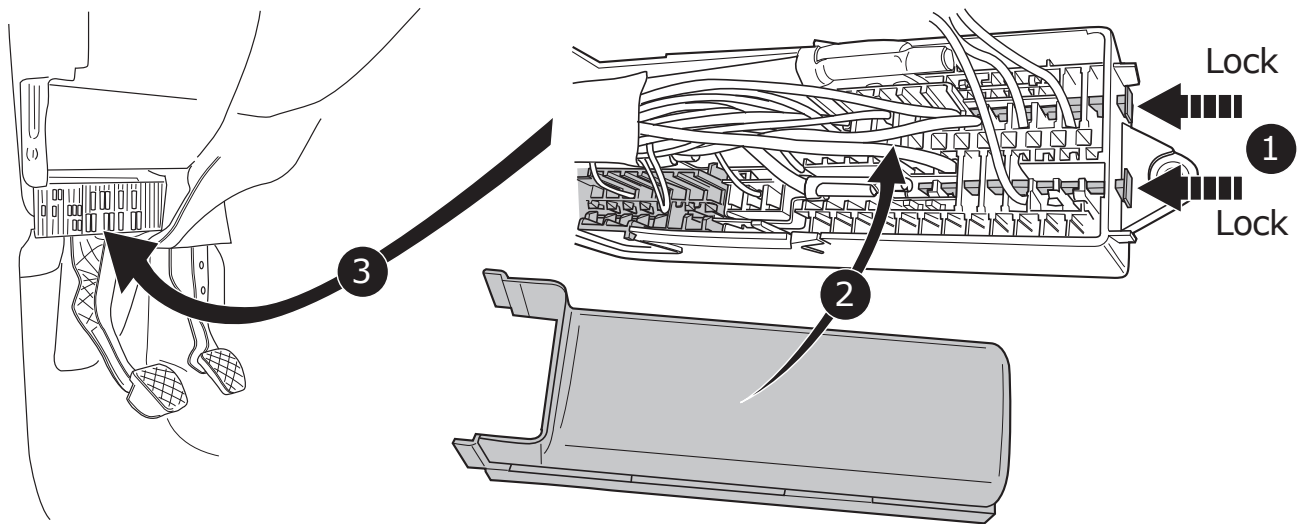

25

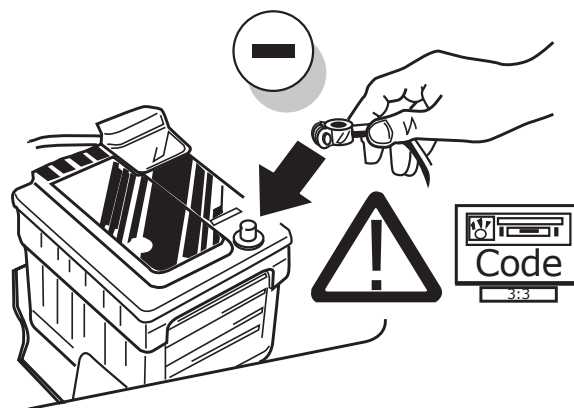

26

A VAG SERVICE TESTER MUST BE USED TO CODE THE VEHICLE'S GATEWAY WITH THE ADDITIONAL FUNCTION FOR THE TOWING HITCH AT THE DEALER.

27

**!** WARNING! IT MUST BE ENSURED THAT ALL THE REQUIREMENTS OF THE VEHICLE MANUFACTURER FOR CHANGES TO AND RETRO-FITTING ON THE VEHICLE AND/OR COOLING SYSTEM FOR THE OPERATION WITH A TRAILER ARE CARRIED OUT.

**■** SUBJECT TO CHANGE.

**!** TEST ALL THE CIRCUITS WITH A TEST DEVICE WITH THE CORRECT POWER LOAD FOR EACH FUNCTION. A TEST DEVICE WITH LED'S CANNOT BE USED FOR THIS PURPOSE.

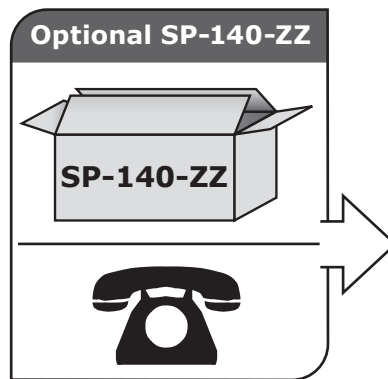
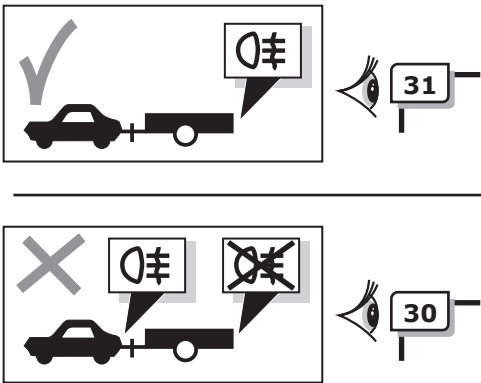

Consult your supplier.

REINSTALL TRIM.

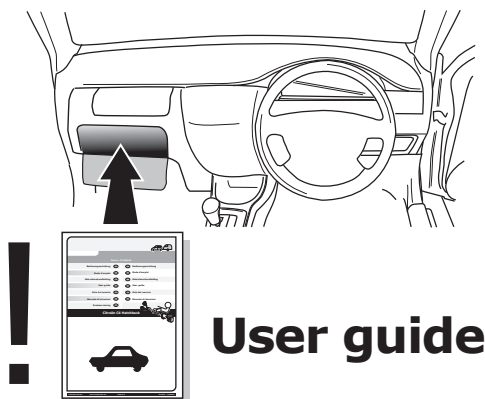

**User guide**





### SOCKET CONNECTION

DIN/ISO 1724							
	1/L	2	3/31	4/R	5/58-R	6/54	7/58-L
Pmax	21W	2x21W		21W	52W	3x21W	52W
Colour	Black/ White	Blue	Brown	Black/ Green	Grey/ Red	Black/ Red	Grey/ Black

### Reverse signal preparation

A

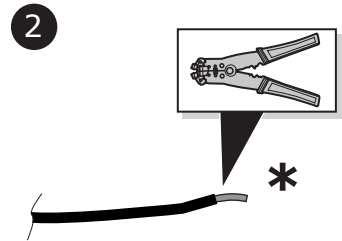
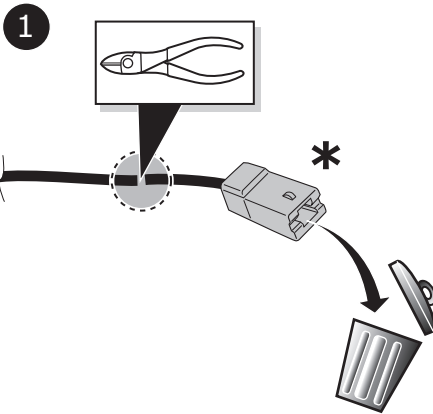
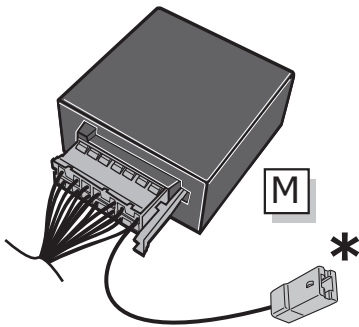

B

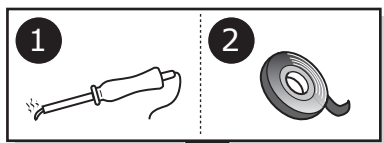

MAX = 21W

